

Power Factor Regulator User's Guide

A BRIEF OVERVIEW

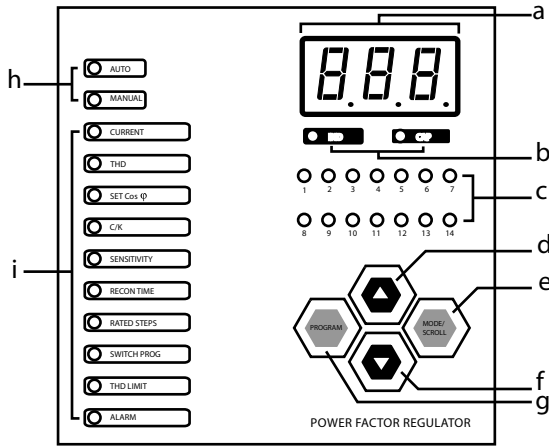

- a - 3-digit numeric display
- b - "CAP " and "IND " indicators(CAP = Capacitive, IND = Inductive)
- c - Step indicator
- d - "UP" button
- e - "MODE /SCROLL " button
- f - "DOWN " button
- g - "PROGRAM " button
- h - "AUTO " and "MANUAL " indicators
- i - Mode indicator

1. General Description

The power factor regulator combines comprehensive operation with user-friendly control setting. It uses numerical techniques in computing the phase difference between the fundamentals of current and voltage, thus precise power factor measurement is achieved even in presence of harmonics.

The power factor regulator is designed to optimize the control of reactive power compensation. Reactive power compensation is achieved by measuring continuously the reactive power of the system and then compensated by the switching of capacitor banks. The sensitivity setting optimizes the switching speed. With the built-in intelligent automatic switching program, the power factor regulator further improves the switching efficiency by reducing the number of switching operations required to achieve the desired power factor.

Usage of the capacitor bank is evenly distributed by the intelligent switching algorithm. This ensures uniform ageing of the capacitors and the contactors used.

The four-quadrant operation feature allows the power factor regulator to operate correctly in the case of active power feed back to the mains where regenerative power sources are used.

Harmonic current in the system can be harmful to the capacitor bank. This power factor regulator is capable of measuring the total harmonic distortion (THD) in the system and produce an alarm if the THD level is higher than the pre-set value. Other alarms include under/over compensate alarm, under/over current alarm and under/over voltage alarm.

Current transformer (CT) polarity is important in determining the correct phase angle different between the current and voltage hence the power factor. This power factor regulator will automatically correct the CT polarity internally in the event that the polarity is reversed.

2. Light indication

The regulator has a 3-digit numeric display and several light indicators of which can be functionally divided into 3 categories:-

- i. Metering functions - power factor, current & THD for current.
- ii. Control parameters functions - power factor, C/K, sensitivity, reconnection time, rated step, switching program & THD Limit.
- iii. Alarm messages function.

To access the above functions, press the "MODE/SCROLL" key until the light indicator is indicating the desired function. The 3-digit numeric display will show the value of the selected function. If there are sub-functions on the selected function such as the function for "rated step" & "alarm messages", press the "UP" or "DOWN" arrow key to access these sub-functions.

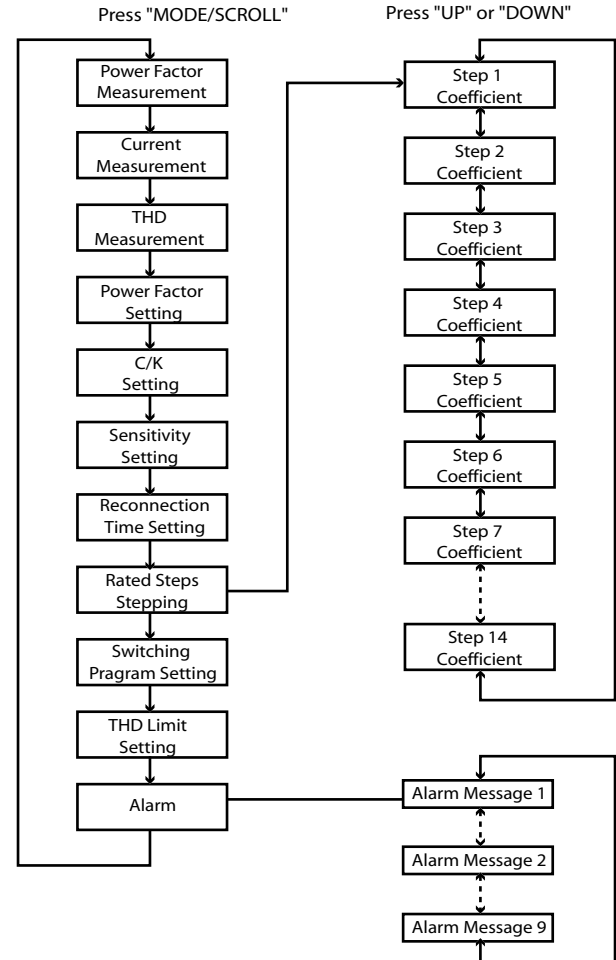

Figure 1: Display Structure

3. Metering function

3.1 Power Factor

Upon powered up, the numeric display indicates the measured power factor of the system. If the "IND" LED lights up, it mean the system is having inductive power factor. On the other hand, if the "CAP" LED lights up, it means the system is having capacitive power factor.

If the power factor regulator detects a re-generative condition where the energy flow is reversed, the power factor display will shown a minus sign in front of the power factor reading.

When the load current is below the operating range and the power factor cannot be measured accurately, the numeric display will shows "---".

If the power factor regulator has been previously set to other display function, it will automatically return to this power factor display function if no key is pressed for more than 3 minutes.

3.2 Current

This function display mode is indicated by the "CURRENT" light indicator. The numeric display shows the true-rms value of the secondary current measured by the 5A current transformer (CT).

Example:

If a 1000/5A CT is used and the display shows "2.50", the primary measured current is 500A.

3.3 Current Total Harmonic Distortion(THD)

This mode is indicated by a "THD" light indicator. The numeric display shows the total harmonic distortion of the current as according to the formula below.

$$THD = \sqrt{\frac{\sum_{n=2}^{\infty} i_n^2}{i_1^2}}$$

$i_n = n^{\text{th}}$ order harmonic current rms
 $i_1 =$ Fundamental current rms

This measurement is possible only if the total load is at least 10% of the rated load. If the THD could not be displayed, the 3 -digit numeric display will show "----".

4. Control Parameters

4.1 Target Power Factor (SET Cos φ)

This set the targeted power factor required when the system is under automatic mode. The power factor regulator will switch the capacitors in or out in order to achieve this set value.

4.2 C/K

This setting is used to set the switching hysteresis and it is calculated based on the smallest size capacitor used.

With automatic C/K selection(C/K set to AtC), the reactive power compensation is achieved without C/K setting. The PFR will measure and evaluate all steps available when necessary and C/K value is then computed.

The C/K value can also be obtained manually from table 1 or calculated with the following formula :-

$$C/K = \frac{Q \times 5}{\sqrt{3} \times V \times I} \approx \frac{2.88 \times Q}{V \times I}$$

where Q = smallest capacitor step (var)

V = nominal primary system voltage (V)

I = primary rating of the current transformer (A)

Example:-

If $Q = 15\text{ kvar}$; $V = 415\text{ V}$; $I = 800\text{ A}$

=> $C/K = (2.88 \times 15000) / (415 \times 800) = 0.13$

C.T.	C/K - Value for 415V											
	Smallest Capacitor In (kvar)											
	2.5	5	10	15	20	25	30	40	50	60	100	150
50 :5	0.35	0.70										
60 :5	0.29	0.58	1.16									
75 :5	0.23	0.46	0.93									
100 :5	0.17	0.35	0.70	1.04								
150 :5	0.23	0.23	0.46	0.70	0.93	1.16						
200 :5	0.12	0.18	0.35	0.52	0.70	0.87	1.04					
250 :5	0.14	0.14	0.28	0.42	0.56	0.70	0.83	1.11				
300 :5	0.07	0.12	0.23	0.35	0.46	0.58	0.70	0.93	1.16			
400 :5	0.04	0.09	0.17	0.26	0.35	0.43	0.52	0.70	0.87	1.04		
500 :5	0.03	0.07	0.14	0.21	0.28	0.35	0.42	0.56	0.70	0.83		
600 :5		0.06	0.12	0.17	0.23	0.29	0.35	0.46	0.58	0.70	1.16	
800 :5		0.04	0.09	0.13	0.17	0.22	0.26	0.35	0.43	0.52	0.87	
1000 :5		0.03	0.07	0.10	0.14	0.17	0.21	0.28	0.35	0.42	0.70	1.04
1500 :5			0.05	0.07	0.09	0.12	0.14	0.19	0.23	0.28	0.46	0.70
2000 :5			0.03	0.05	0.07	0.09	0.10	0.14	0.17	0.21	0.35	0.52

Table 1: C/K Table for 415V

Note: (i) During automatic C/k measurement(C/K set to AtC), any step with C/K value lower than 0.03 may not be detected and will be excluded from the controlling process.

(ii) The user may encounter non-optimized regulating during the initial stage before the C/K value is determined.

4.3 Sensitivity

This parameter set the speed of the switching. A larger sensitivity value will result in slower switching speed and conversely, a smaller sensitivity value will result in a faster switching speed. This sensitivity applies to both switching on and switching off of the capacitor.

Example:- If smallest step, $Q_{1st} = 15\text{ kvar}$; Sensitivity= 60 s/step

Scenario 1:

Reactive power required to achieve set power factor, $Q_{rq} = 15\text{ kvar}$

Step required to achieve target power factor = Q_{rq} / Q_{1st}

= 15kvar/15kvar

= 1 step

Reaction time = 60/1 = 60 sec

Scenario 2:

Reactive power required to achieve set power factor, $Q_{rq} = 45\text{ kvar}$

Step required to achieve target power factor = Q_{rq} / Q_{1st}

= 45kvar/15kvar

= 3 steps

Reaction time = 60/3 = 20 sec

4.4 Reconnection Time

This is the safety lockout time which is used to prohibit the reconnection of the same capacitor step before it is fully discharged. This parameter is usually set larger than the discharge time of the largest capacitor size in used.

4.5 Rated Step

Every step in the power factor regulator is programmable except Step 1. Step 1 is fixed as "1" and it is the smallest capacitor step used. All other steps were programmed as multiple of Step 1.

Example:

If the configuration of capacitors used, starting from Step 1, is 10kvar, 10kvar, 20kvar, 20kvar, 30kvar, 30kvar, 60kvar & 60kvar, then the rated steps are 1, 1, 2, 2, 3, 3, 6, 6.

Unless all steps are fully used, the unused steps should be set as "000". The last step can be programmed as alarm/fan output by setting the step to "ALA" /"FAn". When the last output is programmed as alarm output, second last output can be programmed as fan output.

During the programming of the "Step", the corresponding light indicator for that selected step will light up. Example, number "1" light indicator indicates rated step for contact output number 1.

If the automatic C/K mode is enabled, the PFR will carry out the automatic rated step measurement. Therefore, all steps are not programmable except alarm/fan output.

4.6 Switching Program

This setting allows the selection of one of the four available switching algorithms.

a) Manual switching (n-A):

When this switching program is selected, the capacitor steps are controlled manually by the "UP" or "DOWN" keys. The "UP" key will connect the capacitor step and "DOWN" key will disconnect the capacitor step. Steps are switched in a rotational manner based on first-in-first-out basis.

b) Rotational switching (rot):

This switching program is similar to the manual switching method and it is based on rotational first-in-first-out sequence. Unlike the manual switching program, this option will automatically switch in and out the capacitors according to the targeted power factor, sensitivity setting and the reconnection time setting.

c) Automatic switching (Aut):

This automatic switching program uses intelligent switching sequence. The step switching sequence is not fixed and the program automatically select the most appropriate steps to switch in or out in order to achieve shortest reaction time with minimum number of steps. For equal ageing of the capacitor and contactors, the program will select the least used step to be switched in if there are two equally rated steps.

Under this switching program, the power factor regulator automatically detects the CT polarity during power up. Once this polarity reference is fixed, any subsequent re-generative power condition detected will cause all the capacitor steps to be

d) Four-quadrant switching (Fqr):

This switching program is similar to the automatic switching program (Aut) except that this switching program allows the power factor regulator to operate correctly under both import power and export power (re-generative) conditions. Under export power condition, the active power is fed back to the supply mains by other energy sources such as solar power etc. If this option is selected, the installer must ensure that the CT polarity is correctly wired because the automatic CT polarity correction detection feature is disabled.

The "Manual" light indicator on the power factor regulator lights up if the switching program is set to Manual switching (n-A). For Rotational (rot), Automatic (Aut) and Four-quadrant (Fqr) switching programs, the "Auto" light indicator on the regulator lights up. Under normal operating condition, the step indicators indicate the ON/OFF status of every step. A steady ON light indicates the particular step is switched in. A blinking light indicates that the particular step is required to switch in but unable to do so temporary due to reconnection time lockout.

Please note that all the steps will be disconnected if the power factor regulator detects a re-generative condition under Rotational (rot) or Automatic (Aut) switching program.

4.7 THD Limit

This parameter specifies the limit of total harmonic distortion level before an alarm is activated (More information on section 6). This function can be disabled by setting the parameter to "oFF".

4.8 Procedure for Setting the Control Parameters

Step 1: Select the required item by stepping through all the items using "MODE/SCOLL" key. The corresponding indicator of the selected item will be lit. For "Rated step" setting, the individual output can be selected via the "UP" or "DOWN" keys, the step indicator corresponds to the step number.

Step 2: Press the "PROGRAM" key once, the indicator of the selected item will blink to indicate that the system is now in programming mode.

Step 3: Use the "UP" or "DOWN" keys to select the desired value.

Step 4: To save the selected value, press the "PROGRAM" key once, the indicator stop blinking and the setting is saved.

To abort without saving the selected setting, press the "MODE/SCROLL" key.

Control Parameter	Indication LED	STEP LED*1	Setting Range	Default Factory Setting
Target power Factor	SET Cos Φ		0.80 Ind - 0.80 Cap	0.98 Ind
C/K	C/K		0.03 - 1.20/AtC	AtC
Sensitivity	SENSITIVITY		5 - 300 s/step	45 s/step
Reconnection Time	RECON TIME		5 - 240s	30s
Rated Step*2: Step 1 Step 2 ⋮ Step 14	RATED STEPS	1 2 ⋮ 14	001 - 002 - 003 - 004 - 005 - 006 - 008 - 012 - 016 000 - disable ALA*3 - alarm ouput FAn*4 - fan output	001
Switching Program	SWITCH PROG		n-A - rot - Aut - Fqr	Aut
THD Limit	THD LIMIT		0.20 - 3.00/ oFF	0.50

*1- Under normal operation except for rated step display, the step indicator indicate step ON/OFF status

*2- Number of steps depend on model

*3- Only last output can be configured as alarm output

*4- Last output can be configured as fan output, or second last output can be configured as fan output only when last output is configured as alarm output.

Table 2: Parameters setting

4.9 Reset To Factory Default Setting

To reset all programmable parameters to factory default, first power off the power factor regulator. Press the "UP" & "DOWN" keys simultaneously while turning on the power and holds it for more than 5 sec until the display flashes "dEF" for 3 sec. Now the power factor regulator is restored to factory default setting.

5. Fan Output

When the fan output is selected, the output will be energized with any capacitor bank switched ON.

6. Alarm

Alarm conditions detected by the power factor regulator are indicated by the flashing "ALARM" light indicator. The last step of the regulator, if required, can also be selectively programmed as alarm contact in addition to the "ALARM" indicator. This additional alarm contact is normally open and it closes when alarm is activated.

To view the alarm message, press the "MODE/SCROLL" key until the "ALARM" function is selected. The numeric display will show the alarm message as according to Table 3 below. If more than one alarm messages are recorded, press the "UP" or "DOWN" keys to view the others. The alarm indications are automatically reset to normal once the alarm conditions are restored.

Alarm Message	Description	Delay time		Action	Alarm outputs	
		Activate	Deactivate		LED	Relay
thd	Current THD exceed set THD Limit	5 min	2.5 min	*5 All steps disconnected	Blinks	On
LoI	Current lower than 3% rated value	10 s	5 s	-	Blinks	-
HiI	Current exceed 110% of rated value	2 min	1 min	*5 All steps disconnected	Blinks	On
LoU	voltage lower than 85% of rated value	100 ms	5 s	-	Blinks	On
HiU	Voltage exceed 110% of rated value	15 min	7.5 min	-	Blinks	On
UCo	All capacitors are connected and the power factor lower than set power factor	15 min	7.5 min	-	Blinks	On
OCo	All capacitors are disconnected and the power factor higher than set power factor	15 min	7.5 min	-	Blinks	On
ESt	Auto C/K or rated step measurement error. Manual setting required	-	-	-	Blinks	-
ECt	Automatic CT polarity detection error	-	-	-	Blinks	-

*5- Automatic switching of steps are prohibited when this alarm occurred.

Table 3: Alarm table

7. Automatic CT polarity detection

During the power on start-up process, the power factor regulator, if programmed under Rotational or Automatic switching program, detects the CT polarity and correct it internally if the CT polarity is reversed. If the power factor regulator is set for Four-quadrant switching program, this feature is disabled.

8. Programming Lock

The power factor regulator is equipped with a programming lock to prevent inadvertent changes to the control parameters. If locked, all the control parameters can only be viewed at and cannot be changed without unlocking it first.

To lock or unlock, first ensure that the display is on the power factor display function mode, then press "PROGRAM" key once followed by "DOWN" key immediately. Hold the "DOWN" key until the numeric display flashes "LOC" or "CLr". "LOC" indicates the power factor regulator is locked and "CLr" indicates the regulator is unlocked.

9. Technical Data

9.1 Auxiliary Supply

Supply voltage	: 220VAC / 415VAC
Operating Limits	: -15% + 10%
Consumption	: 10VA max
Frequency	: 50Hz or 60Hz

9.2 Current Input

Rated current, I_n	: 5A
Operatings Limits	: 0.15A - 6.5A
Rated Frequency	: 50Hz or 60Hz

9.3 Relay Output

Numbers of outputs	: 6 / 8 / 12 / 14 (PFR60 / PFR80 / PFR120/ PFR140)
Contact arrangement	: NO contact type
Rated capacity	: 5A 250VAC (Cos ϕ = 1)
Max current for the common terminals	: 12A continuous

9.4 Control Range

Power factor setting	: 0.8 inductive - 0.8 capacitive
C/K setting	: 0.03 - 1.00
Switching sensitivity	: 5 - 600 s/step
Reconnection time for same step	: 5 - 240 s
THD threshold	: 0.20 - 3.00 (20% - 300%) / OFF
Switching Program	: Automatic / Automatic Rotate / Manual/ Four- quadrant
Rated step coefficient	: 0 / 1 / 2 / 3 / 4 / 6 / 8 / 12 / 16

9.5 Mechanical

Mounting	: Panel mounting
Dimension (h X w X d)	: 144mm X 144mm X 91mm
Approximate weight	: 1kg

10. Typical Application Diagram

10.1 Diagram 1 - Without external discharge resistors

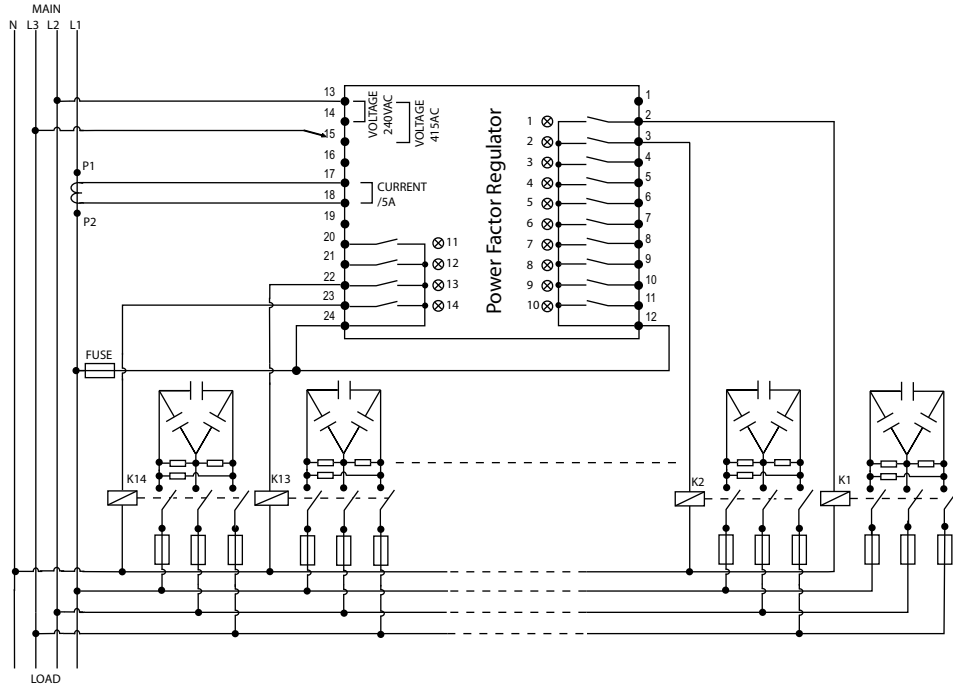

10.2 Diagram 2 - With external discharge resistor

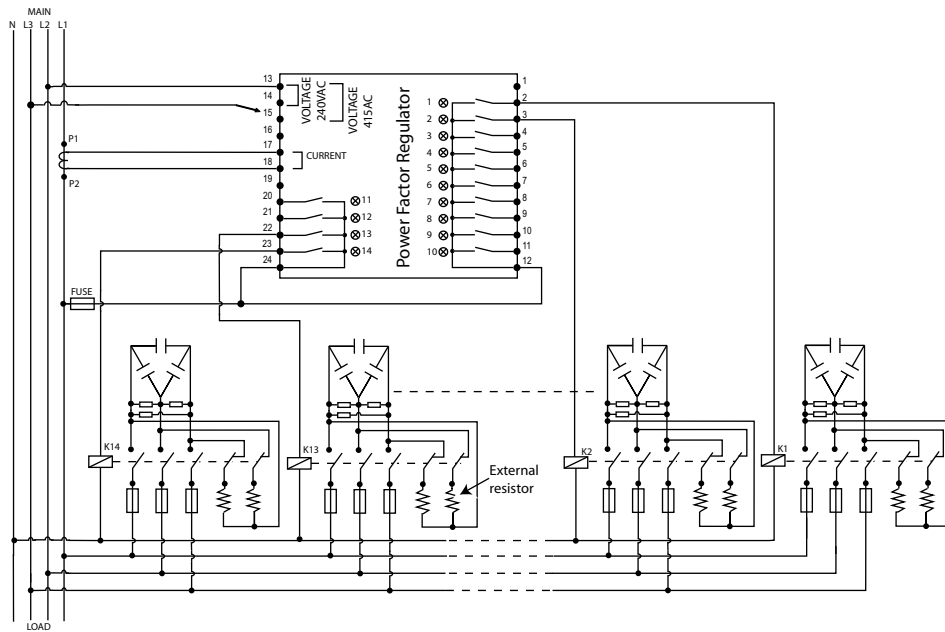

11. Case Dimensions

