

Numerical based
EARTH LEAKAGE RELAY



FEATURES

- Numerical Based
- True RMS measurement
- Low / High set
- Auto Z.C.T. connection check (open/short)
- Operation hour recording
- Fault / Trip LED indication
- Trip value recording (3 memory)
- Total trip count information
- Programmable relay output
- Programmable software lock
- Din-rail mount

Specification

Technical data / Setting range

Measurement	True RMS Ampere
Power Supply	240 VAC (±10%) or others on request
Rated Current (In)	. . / 5A (same phase with power supply)
Rated Frequency	50 ~ 60 Hz
Output Relay / Alarm	5 A / 250 VAC
C.T. Input / Burden	... / 5A / 1 VA
Tripping Contact	SPDT 5A/240V AC K1 : Latching Trip K2 : Programmable
Min. Sensitivity	~ 0.5%
Weight	~ 320 g
Operating Temperature	0° to + 55° C
Standard	IEC : 61000-4-2 / 4-4 / 4-5 / 255-5:1

Current Setting Range : $I_{\Delta n} > (A)$	0.03 ~ 30.0 Ampere
Time Setting Range (sec): $t > (\text{sec})$	0.03 ~ 10.0 (0.1 sec. step)
High Set Range : $I_{\Delta n} >> (A)$	OFF or 5 ~ 50 Ampere (1 Amp. step)
High Set Trip Time : $t >>$	Fixed at 50ms
Display Range (In)	0.0% ~ 500%
Relay Operation Level	$I_n / I_s > = 1.0$

Manual Test Trip / Reset Trip Memory

To do a test trip of the device / To reset the trip memory

Manual test trip allows the user to test device for any fault in tripping. To do a manual test trip, follow the instructions below:

- When no mode is selected (mode display is blank)
 - i) Press & hold the [**Test**] button for 5 secs.
 - ii) Release when the display shows ' **t-r** '.
 - iii) Mode starts to count down from 5 and trips at zero, the display shows ' **t-r 0** '.

To abort test,

Press the [**Cancel**] button once (when mode has not counted down to zero)

To reset the trip memory :

To reset the trip memory of the device, press [**Select**] button to go to mode [**A**].

If the display shows ' --- ' (NO tripping has occurred), no resetting is needed. If the display show a certain value (tripping has occurred), then follow the steps below :

- Press [**UP / (+)**] and [**Down / (-)**] button simultaneously and hold for 5 seconds. The display will reset to show ' --- '.
- To exit, press [**Cancel**] button.

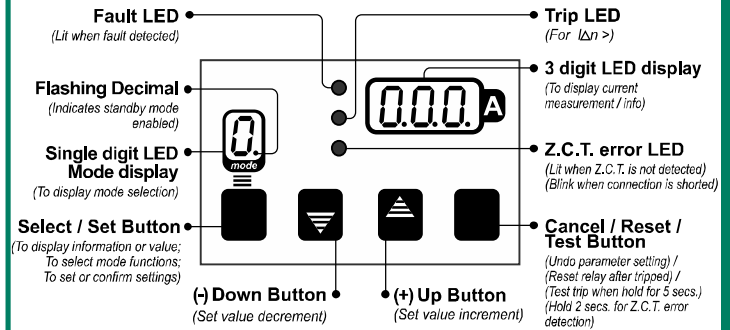

Parameter Modes Definition

Modes definition

1 ~ 3 :	f $I_{\Delta n} > (A)$	To set leakage current
For Setting (Adjustable)	2 $t > (\text{sec})$	To set trip time
	3 $I_{\Delta n} >> (A)$	To set high-set leakage current
9 ~ d :	9 Operation hr.	Device operated in hours (x 1000 hr.)
For Viewing (Not Adjustable)	A Trip memory 1	Most recent trip value
	b Trip memory 2	Trip value before (Trip mem.1)
	c Trip memory 3	Trip value before (Trip mem.2)
	d Total trip count	Total number of trips
L / r / - :	L Software lock setting	Keypad lock mode
For Setting (Adjustable)	r Relay K2 function	Programmable alarm output
	- Standby mode	Running LED bar

Wiring Diagram

Wiring connection (Earth Leakage Relay : Din-rail type)

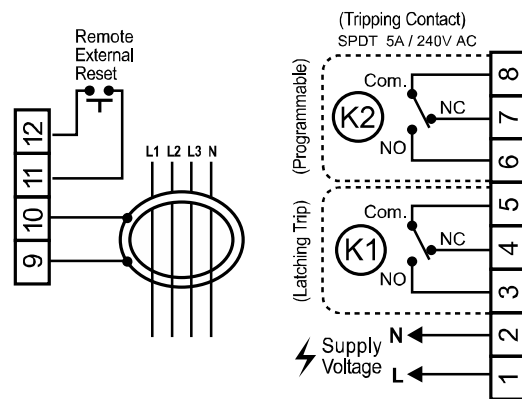

Casing Dimension

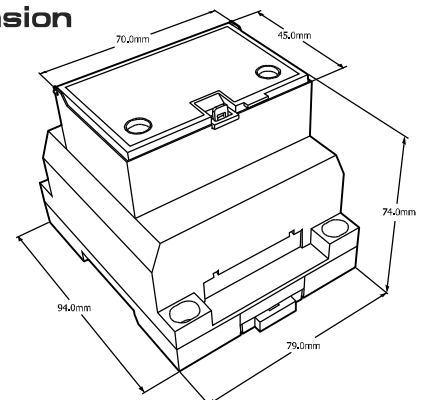

How to do setting

To go to the MODES for setting of parameters

Press 'Select' button when mode display is blank to access to Parameter Setting mode.

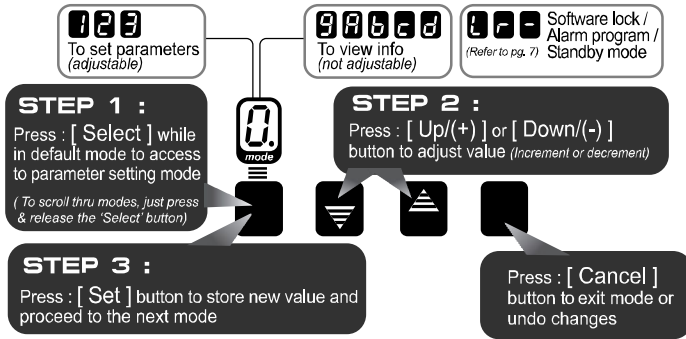

All modes exit automatically if left untouched for more than 20 seconds.
(For fast increment or decrement, press and hold the UP or Down button)

mode 1 IΔn> : To set leakage current (A)

- Step 1 :** Press [Select] once to enter mode 1.
Display shows : 0.50 - Factory Default Setting (Range : 0.03 ~ 30.0 Ampere)
- Step 2 :** Set the desired leakage current using the [Up / (+)] or [Down / (-)] button.
Newly selected value will flash.
- Step 3 :** Press [Select] to store / confirm new value and advance to mode 2 or press [Cancel] to undo changes.

mode 2 t > : To set trip time (sec.)

- Step 1 :** Press [Select] until mode 2 is displayed.
Display shows : 0.3 - Factory Default Setting (Range : 0.03 ~ 10.0 seconds)
- Step 2 :** Set the desired trip time using the [Up / (+)] or [Down / (-)] button.
Newly selected value will flash.
- Step 3 :** Press [Select] to store / confirm new value and advance to mode 3 or press [Cancel] to undo changes.

mode 3 IΔn>> : To set High-set leakage current (A)

- Step 1 :** Press [Select] until mode 3 is displayed.
Display shows : OFF - Factory Default Setting (Range : 5 ~ 50 Ampere or OFF)
- Step 2 :** Set the desired high-set leakage current using the [Up / (+)] or [Down / (-)] button.
Newly selected value will flash.
- Step 3 :** Press [Select] to store / confirm new value and advance to mode 4 or press [Cancel] to undo changes.

mode 4 Operation Hour x1000

This mode is not adjustable. For user to view the no. of hour the device in used only.
Press [Select] until mode 4 is displayed.
Display shows : '0.00' - Number of hour the unit is in used. To exit, press [Cancel].
e.g. 0.05 x 1000 = 50 hours

mode ABC Trip Memory (3 tripping memories)

This mode is not adjustable. For user to view tripped value only.
Press [Select] until mode A is displayed.
The display will show the most recent tripped value.
Press [Select] again to go to mode B, the display will show the tripped value before A.
Press [Select] again to go to mode C, the display will show the tripped value before B.
To exit, press [Cancel].

mode d Total Trip Count / How To Reset

This mode is not adjustable. For user to view the total number of tripping that has occurred. (maximum = 255)
Press [Select] until mode d is displayed.
Display shows : '0' - Number of trips occurred. To exit, press [Cancel].
To Reset Total Trip Count :
Press [Up / (+)] and [Down / (-)] button simultaneously and hold for 5 seconds in current mode (mode d).

mode L Keypad Lock / Programmable Alarm Output

To prevent unauthorized setting / To set alarm warnings

User can lock the keypad on the device to avoid unauthorized or accidental adjustment to the settings by following the steps below:

When NO mode is selected (mode display is blank),

Press [Select] and [Cancel] button simultaneously and hold for 5 seconds.

L - mode is displayed (Lock mode).

Display shows : OFF - Factory Default Setting (OFF or ON).

Press [Up / (+)] or [Down / (-)] button to select 'ON' or 'OFF'. When lock mode is set to 'ON', modifying of set values are not allowed (Mode 1 to 3). Display will show - Loc- when user tries to modify value.

Press [Set] button to confirm and go to 'r' mode.

r - mode is displayed (Relay output alarm mode).

Display shows : LC - Factory Default Setting. (See table below)

Press [Up / (+)] or [Down / (-)] button to select one of the 5 relays alarm mode.

This programmable output is for relay function K2 only.

Press [Set] button to confirm and proceed to ' - ' mode.

5 Programmable Relay Alarm Output

- L - Latching Trip
- ALL - All Alarm (Z.C.T./Tripped)
- nL - Non-latching Trip
- FS - Failed Safe Trip
- ct - Z.C.T. Error

mode - Standby

To enable / disable standby mode

- mode is displayed (Standby mode).

Display shows : ON - Factory Default Setting (ON or OFF).

Press [Up / (+)] or [Down / (-)] button to enable / disable standby mode.

Press [Set] button to confirm and exit.

A flashing decimal on the mode display indicates standby mode is enabled. After about 3 minutes of idle and no fault is detected, running LED bar will be displayed instead of the real time fault current.

Standby mode automatically exits on fault detection or when any button is pressed. When device trips, standby mode is temporarily de-activated until device is reset.

Alternatively, to enable / disable standby without entering standby programming mode, simply press [Reset] button when powering up the device.

Z.C.T. Error Detection

Automatic check at 2 hour interval.

For manual check, press & hold the [Test] button for 2 secs.

- If Z.C.T. connection is open, Z.C.T. error LED will lit.

- If Z.C.T. connection is shorted, Z.C.T. error LED will blink.

Z.C.T. Dimension

Zero Phase Current Transformer

For optimum performance and accuracy, we recommend that you use only the original Z.C.T. intended for use with the device. Using others Z.C.T. could compromise on the performance or accuracy. The warranty does not cover product failures which have been caused by use of other Z.C.T.

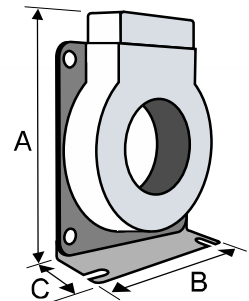

(Type)	ZPC-35	ZPC-50	ZPC-100	ZPC-140	ZPC-200
Hole Diameter (mm)	35	50	100	140	200
A (mm)	82	125	183	235	306
B (mm)	103	112	153	175	255
C (mm)	26	35	35	40	45
Weight (kg)	~ 0.30	~ 0.70	~ 1.40	~ 2.2	~ 4.6
Frequency	50 / 60 Hz				
Current Ratio	200 / 1.5				
Insulation	600V / 50 Hz 1 min.				
Sec. Burden	10 VA				

Contact your supplier for more information.