

2011.05

AIR CIRCUIT BREAKER





SHIHLIN ELECTRIC & ENGINEERING

Contents

1. BA series specification	2
2. General information	3
2.1 Purpose	3
2.2 Model and implication	3
2.3 Classification	3
2.4 Conditions of use	3
3. Structure specifications	4
4. Intelligent controller	5
5. Time/Current curve	14
5.1 ACB Operating curves	14
5.2 Controller (IEC 60255 standard)	16
6. Accessories and functions	22
6.1 Shunt release, Undervoltage release, Motor-driven mechanism, Closing electromagnet	22
6.2 Auxiliary contacts	22
6.3 Mechanical interlocks	23
7. Secondary connection diagram	25
7.1 KST45-M series intelligent controller	25
7.2 Electric controller	27
7.3 ATS	29
8. Outline and installing dimension	30
8.1 Withdrawable circuit breaker	30
8.2 Fixed circuit breaker	33
8.3 Dimension of drilling compartment door and installment pitch of holes	34
9. Mounting, usage and maintenance	35
9.1 Mounting	35
9.2 Usage of intelligent controller	35
9.3 Plugging into the breaker and drawing out the breaker	51
9.4 Maintenance	52
10. Regular failure and obviate methods	53
11. Order	54

1. BA series specification

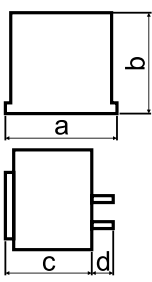
Frame (AF)		2000 - AF				3200 - AF				4000 - AF		5000 - AF		6300 - AF		
Type		BA2000 - H				BA3200 - H				BA4000 - H		BA5000 - H		BA6300 - H		
Feature																
Type		Fixed Type		Drawout type		Fixed Type		Drawout type		Drawout type						
Rated Current (In)A		630.800.1000. 1250.1600.2000.				2000.2500.3200.				4000.		5000.		6300.		
Adjustable Range of Rated Current (A)		0.4~1.0In														
Max. Rated Voltage (Ue) 50/60HZ V		AC 690														
Rated Insulated Voltage (Ui) 50/60HZ V		AC 1000														
Rated Impulse Withstand Voltage (Uimp) kV		DC 12														
Pole		3	4	3	4	3	4	3	4	3	4	3	4	3	4	
N Pole Rated Current (In) A		—	100%	—	100%	—	100%	—	100%	—	100%	—	100%	—	100%	
Rated breaking capacity (kA)	IEC 60947-2 CNS 14816-2 Icu/Ics kA	*AC 690V		50 / 33				65 / 43				—				
		*AC 440V		75 / 48				85 / 55				100 / 100				
		AC 380V		85 / 55				100 / 65				130 / 130				
		*AC 220V		150 / 95				170 / 110				200 / 200				
Rated short time withstand capacity (Icw) kA(1/3 sec)		55 / 50				65 / 60				100 / 100						
Electrical Control Type	Standard Type (M Type)		●													
	Communication Type (H Type)		●													
Electrical Life (Times)		10000														
Bus bar connection type		Horizontal / Vertical				Horizontal				Horizontal						
Dimensions (mm)		Horizontal	a	360	455	375	470	420	535	435	550	815	930	815	930	930
			b	405	405	439	439	405	405	439	439	439	439	439	439	439
			c	295	295	383.5	383.5	295	295	383.5	383.5	383.5	383.5	383.5	383.5	383.5
			d	60	60	67.5	67.5	75	75	82.5	82.5	100	100	100	100	100
		Vertical	a	360	455	375	470	—				—				
			b	405	405	439	439	—				—				
			c	295	295	295	295	—				—				
			d	66	66	66	66	—				—				
Auxiliary Switch (Standard Device)		4C														
Motor drive		AC 110 / 220 / 380V DC 110 / 220V (Optional)														
Optional accessory	Under-voltage Trip (UVT)		AC 110V / 220 - 230V / 380-400V (Optional)													
	Manual Program Editor		English Version													
	ST-DP Interface		●													
	ST Power Module		●													
	Power ZCT		●													

Note: The rated breaking capacities indicated by voltage which marked with * are for reference.

2. General information

2.1 Purpose

Shihlin's BA series of universal circuit breakers (hereafter refers to as breaker) are available in the circuit of AC 50Hz with rated voltages of 400V, 690V and rated continuous current from 630A to 6300A.

The BA offers electric energy distribution and circuit protection, making it the ideal solution for current supply device damages which made by overload, under-voltage, short-circuit and single-phase earthing in distribution network. It is suitable for intelligent and selective protection with accurate action to improve power distribution reliability and avoid unnecessary power cuts.

2.2 Model and implication

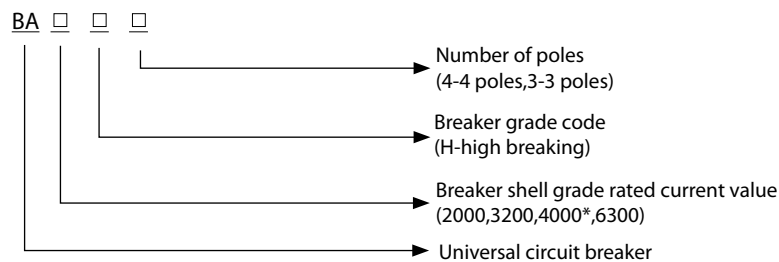

Note: *is capacitance increase style of 3200A shell grade, 4000A just available for 3 poles.

2.3 Classification

- 2.3.1 Mounting type: withdrawable and fixed.
- 2.3.2 Operation mode: motor-driven and manual operation (applicable to overhauling and maintenance)
- 2.3.3 Number of poles: 3 poles and 4 poles.
- 2.3.4 Tripping categories : intelligent release, under voltage instantaneous (or delay) release and shunt release.
- 2.3.5 Intelligent controller, which divided rationally into two parts according to protection features and auxiliary functions: 2M, 2H.
- 2.3.6 Under-voltage release works as self-priming with two kinds: instantaneous and delay.

2.4 Conditions of use

- 2.4.1 Ambient temperature: from -5°C to $+40^{\circ}\text{C}$
 Note: (1) It has to point out while ordering if the lower limit of the working condition is -10°C or -25°C .
 (2) It should negotiate with us if the temperatures higher than $+40^{\circ}\text{C}$ or lower than -25°C .
- 2.4.2 Up to an altitude of 2000m, breaker rated performances are unaffected.
- 2.4.3 Atmospheric conditions: Relative humidity could not exceed 50% while temperature in the surrounding atmosphere is $+40^{\circ}\text{C}$. High humidity is permissible in low temperature condition. The highest monthly average relative humidity could be 90% when the lowest monthly average temperature is 25°C . Notice the sinveler on the products caused by temperature variation.
- 2.4.4 Level of pollution: 3.
- 2.4.5 Mounting categories: IV mounting mode is available for breakers, whose rated voltage under 690V, the under-voltage release coil and the primary coil of the power transformer. In addition, III mounting mode is for auxiliary and control circuit.
- 2.4.6 Mounting conditions: Consult this instruction for information on how to install the breakers.

3. Structure specifications

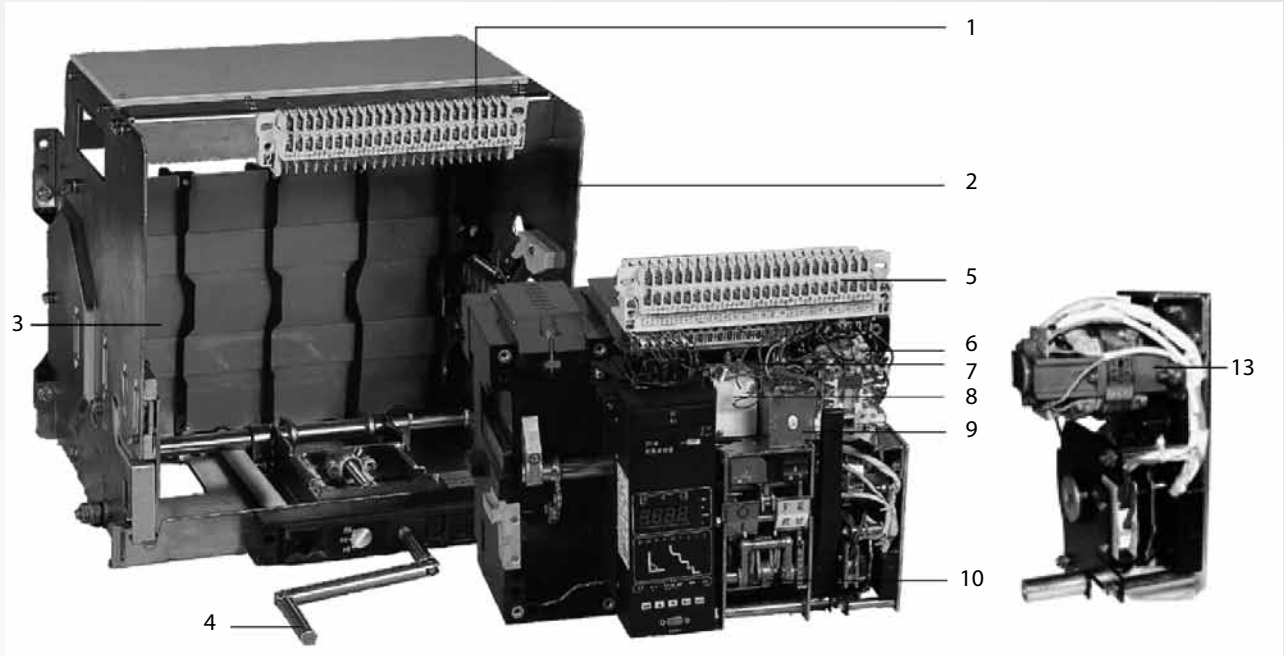

1. Secondary circuit terminal (stationary)
2. Drawer seat
3. Safe separator plate
4. Handle
5. Secondary circuit terminal (movable)
6. Auxiliary contacts
7. Under-voltage release
8. Shunt release
9. Closing electromagnet
10. Operation mechanism
11. Intelligent controller
12. Panel
13. Motor-driven mechanism

4. Intelligent controller

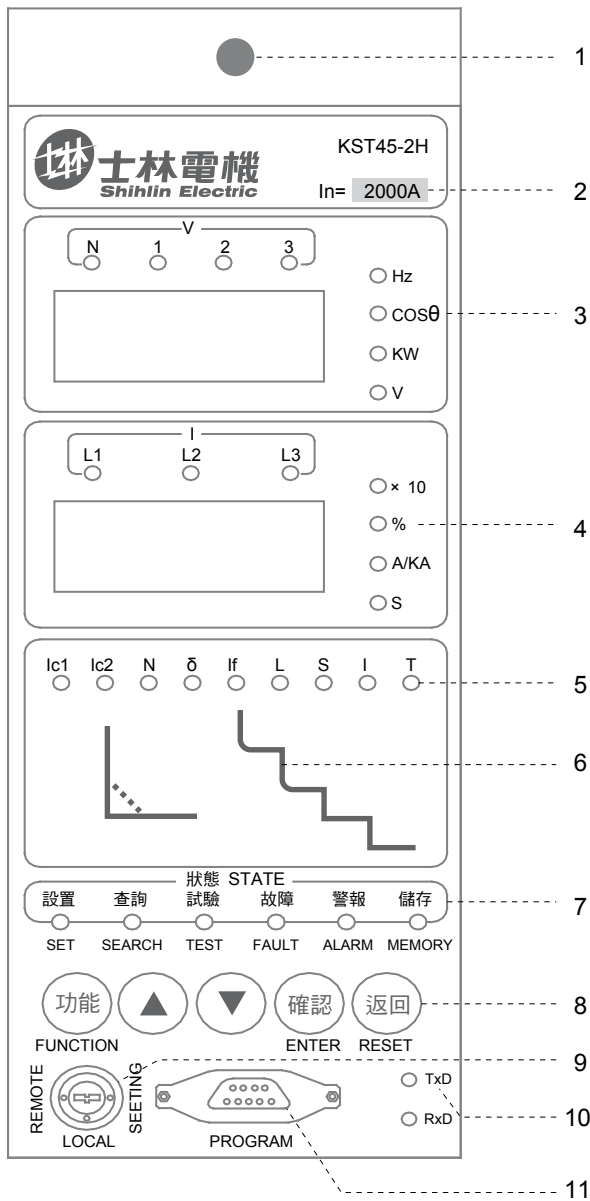

1. Mechanical reset button
2. Rated current indicator
3. Function window
4. Ammeter window
5. Protection category indicator
6. Protection characteristic curves
7. Status indicator
8. Function key
9. Position lock
10. Communication indicator
11. Programming interface

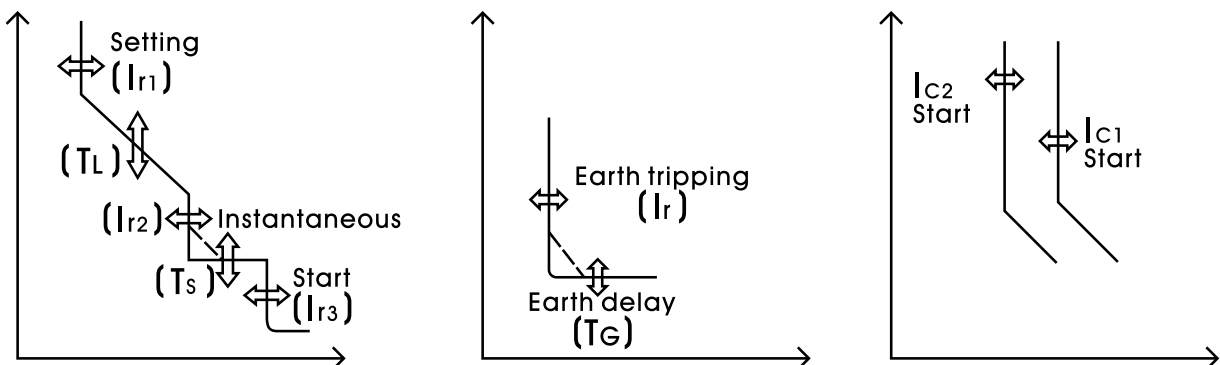

4.1 Intelligent controller function

4.1.1 Protection features

4.1.1.1 Overload long time-delay trip protection features

Table 1 for reference of technical parameters of overload long time-delay protection features

Table 1: Technical parameters of overload long time-delay protection features

Power distribution or motor protection	Setting current value	$I_{r1}=I_n \times \dots$	0.4 ~ 1+OFF (Exit)
		Operating characteristic	$\leq 1.05 I_{r1} : >2h$ no tripping
	$> 1.30 I_{r1} : <1h$ tripping		
	Inverse time delay setting value t_L (s) (corresponding to $2I_{r1}$)	Characteristic curve	Curve 1 ~ Curve 6* (settable) Factory default set curve 3
		Curve rate	IEC60255 standard, total 96 intervals, settable
		Precision	$\pm 10\%$ (Fixed 40ms)
Generator protection	Setting current value	$I_{r1}=I_n \times \dots$	0.4 ~ 1.25 +OFF (Exit)
		Operating characteristic	$\leq 1.05 I_{r1} : >2h$ no tripping
	$> 1.20 I_{r1} : <1h$ tripping		
	Inverse time-delay setting value t_L (s) (corresponding to $2I_{r1}$)	Characteristic curve	Curve 1 ~ Curve 6* (settable) Factory default curve 3
		Curve rate	IEC60255 standard, total 96 intervals, settable
		Precision	$\pm 10\%$
N-phase protection	Setting coefficient*	100% or 50% (supple to 3P+N or 4P)	
	Operating characteristic	The same protection features as A, B, C three-phase	
Thermal memory (30min, clean out while power off)			Standard+OFF

Note : The setting coefficient of N-phase protection is 50%, then the setting value of N-phase protection becomes 50% of total A, B, C 3-phase. Take setting current value of long time delay as 1600A as a sample, for N-phase, its value is 800A.

4.1.1.2 Short-circuit short time-delay protection features

Short time protection has two modes:

1. Inverse time protection: when the fault current exceeds setting current value of definite time, if it is curve(1 ~ 5), controller protects according to the curve (1 ~ 5) of overload long time delay, but the speed 10 times of it. (In other words, it equals to the tenth of the delay tripping time, which computed from the overload long time curve expression.) If it curve6, then calculate the inverse time delay tripping time from the expression of short-circuit shot time delay curve 6 characteristic.
2. Definite time protection: when the fault current exceeds definite time current setting value, controller protects as definite time delay setting value.

Note : If setting current value of inverse time sets on the position of "OFF" or if definite time setting current value is less than or equal to inverse time setting current value, then controller protects according to definite time protection, and the inverse time trip automatic avoidance. If definite time works, tripping time of the short time delay is greater than or equal to setting value of definite time delay, no matter definite time or inverse time. Else, definite time exits, delay tripping time of inverse time protection would not restrict by definite time delay setting value.

Table 2 for reference of technical parameters of Short-circuit short time-delay protection features

Table 2: Technical parameters of Short-circuit short time-delay protection features

Current setting value of inverse time and definite time	$I_{r2}=I_{r1} \times \dots$	1.5 ~ 15 + OFF (Exit)
	Operating characteristic	$\leq 0.9 I_{r2}$: no tripping $>1.1 I_{r2}$: delay tripping
Setting value of definite time delay: t_s	t_s (s)	0.1 ~ 1(0.1 interval)
	Precision	$\pm 10\%$
Inverse time protection feature	1 ~ 5 curves are the same overload long time delay, but curve speed is 10 times.	
	Curve 6 characteristic express: $T_s=64t_s/ N^2$ that is $T_s=t_s \times (8I_{r1}/I)^2$	
Inverse time thermal memory (15 min, clean out when power off)	Standard+ OFF	

4.1.1.3 Short circuit instantaneous protection features

Table 3: Technical parameters of short circuit instantaneous protection features

Setting current value	Ir3	1.0 In~50kA/75kA/100kA + OFF (EXIT)
	Operating characteristic	≤ 0.85 Ir3 no tripping
		>1.15 Ir3 tripping
Actuation time		< 100ms (Including original break time of the circuit-breaker)

Note : If the controller is Frame I, the setting values of instantaneous protection is 1.01 In ~ 50kA +OFF. If it is Frame II, that setting value is 1.01 In ~ 75kA +OFF. And 1.01 In ~ 100kA +OFF as Frame III.

4.1.1.4 Unsymmetrical earthing or leakage protection features

Table 4: Technical parameters of Unsymmetrical earthing or leakage protection features

Earth fault protection	Setting current	I _r = I _n × ...	0.2 ~ 1 +OFF (Minimum 100A, OFF means exit)
		Operating Characteristics	<0.8 I _r : no tripping
	≥ 1.0 I _r : delay tripping		
	Time delay(s)	Definite time-delay T _G (s)	0.1 ~ 1 +OFF (0.1 interval, OFF means alarming without tripping)
		Inverse time coefficient K _G	1.5 ~ 6 +OFF (0.5 interval, OFF means earthing as definite time mode)
Precision		± 10%	
Leakage protection	Setting current	I _r = I Δ x ...	0.1 ~ 1.0+OFF (0.01A interval, OFF means exit)
		Operating characteristics	<0.8 I _r : no tripping
	≥ 1.0 I _r : delay tripping		
	Time delays(s)	Definite time-delay T _G (s)	0.1 ~ 1 +OFF(0.1 interval, OFF means alarming without tripping)
		Inverse time coefficient K _G	1.5 ~ 6 +OFF(0.5 interval, OFF means earthing as definite time mode)
Precision		± 15%	

It is just available one between earth fault protection and leakage protection.

There are two styles of above two protections:

1. Inverse time protection: $T_G = t_G \times K_G \times I_f / I$

In the expression: T_G defines as delay actuation time of actual protection

t_G defines as setting value of definite time delay

K_G defines as coefficient value of inverse time

I_f defines as setting current value

I defines as real working current

Delay actuation time of inverse time protection could be obtained from above expression, but it is greater than or equal to setting value of definite time delay. It is definite time protection when K_G is in OFF position.

2. Definite time protection: delay actuation time of definite time protection is definite time delay setting value.

Single earthing protection is a kind of metallic protection when fault current exceeds several hundreds ampere, which generally applied to neutral –point directly earthing system. There are two kinds of protection modes for the controller:

One is vector sum mode of internal transformer (earthing protection). The controller's operating apply to vector sum of the three-phase current and neutral current, according to the numbers of poles of breaker, there are three forms: 3PT, 4PT, (3P+N) T. This mode widely used for balance overload, unbalanced overload and motor overload systems with alarming no tripping.

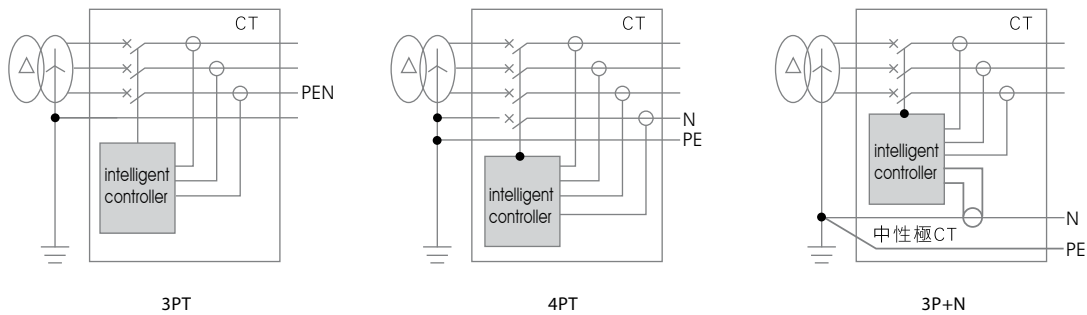

Another is transformer mode of external leakage. The controller gets the output current signal from a current transformer directly to protect. Generally, the secondary output of the transformer is 5A/1A (secondary current is 1A if primary current of transformer is less than 400A, else is 5A). This mode has higher sensibility especially applied to protect earth fault whose current is smaller beginning from tens of amperes. There are two methods of ground signal's sampling. One is rectangular transformer sampling mode (shown as follow Mode1, Model 2). Another is ring transformer sampling mode in which the transformer's diameter is 100MM (Mode 3 for reference)

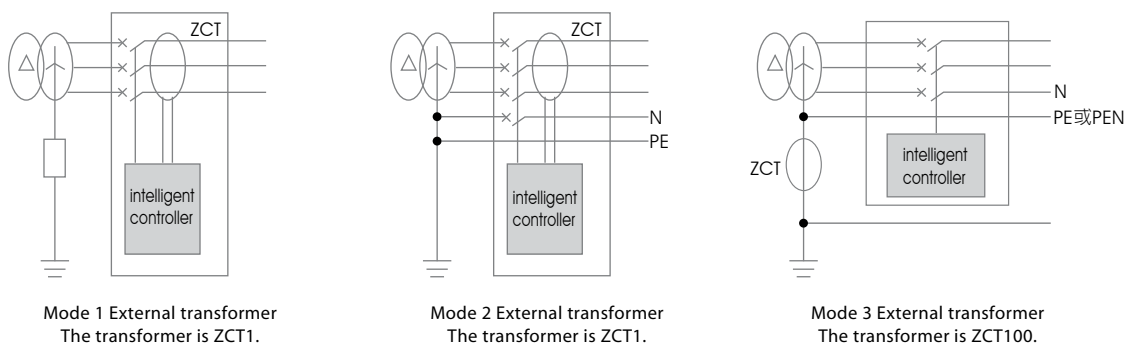

Mode 1 External transformer
The transformer is ZCT1.

Mode 2 External transformer
The transformer is ZCT1.

Mode 3 External transformer
The transformer is ZCT100.

(1) Specification of ZCT1 transformer

Primary current	200A	400A	600A	1000A	2000A
Secondary current	1A	1A	5A	5A	5A

Note : 1. 200-400A/1A and 600-2000A/5A are customizable.

2. ZCT1 supplies bus bar through layout for Frame I. If ZCT1 is chosen for Framell and Frame III, then use the way of pulling on cables.

(2) Specification of ZT100 transformer

Primary current	200A	400A
Secondary current	1A	1A

4.1.1.5 Overload supervision and control protection features

Table 5 for reference of technical parameters of short circuit instantaneous protection features

Controller is programmed output two passive signal contacts, which can charge of overload supervision and control, they are use for alarming, break the overload circuit and keep the main system normal power supply.

User can pick one of these two supervision patterns:

Pattern 1: control overload of two –sub-circuit, controller output the signal contracts in the light of inverse time delay respectively when the working current exceeds $1.2 I_{c1}$ or $1.2 I_{c2}$. Characteristic curve of inverse time equal to characteristic curve of overload long time delay, meanwhile, it is settable for curve slop and setting current value.

Pattern 2: control overload of sub circuit, if the running current surpasses $1.2 I_{c1}$, signal contracts will set out to break sub circuit over overload by controller's action, which is according to inverse time delay characteristic. Characteristic curve of inverse time equal to characteristic curve of overload long time delay, it is settable for curve slop and setting current value when setting value $I_{c1} > I_{c2}$. If the running currents recover after breaking sub circuit overload, the current lower than the setting value I_{c2} lasting 60s, the controller sends out a signal contact again to pick up broken overload and restore the power supply of system.

Table 5: Technical parameters of short circuit instantaneous protection features

Pattern 1	Setting current value	$I_{c1} = I_n \times \dots$	0.2 ~ 1+OFF (min 100A, OFF means exit)
		Output characteristic	$\leq 1.05 I_{c1}$: non making $> 1.2 I_{c1}$: delay relay making
	Inverse time delay (s)	Characteristic curve	The same as overload long time delay characteristic curve
		Curve rate	Set separately (setting coefficient equals to overload long time delay)
	Setting current value	$I_{c2} = I_n \times \dots$	0.2 ~ 1+OFF (min 100A, OFF means exit)
		Output characteristics	$\leq 1.05 I_{c2}$: non making $> 1.2 I_{c2}$: delay relay making
	Inverse time delay (s)	Characteristic curve	The same as overload long time delay characteristic curve
		Curve rate	Set separately (setting coefficient equals to overload long time delay)
Pattern 2	Setting current	$I_{c1} = I_n \times \dots$	0.2 ~ 1+OFF (min 100A, OFF means exit)
		Output characteristic	$\leq 1.05 I_{c1}$: non making $> 1.2 I_{c1}$: delay relay making
	Inverse time delay (s)	Characteristic Curve	The same as overload long time delay characteristic curve
		Curve rate	Set separately (setting coefficient equals to overload long time delay)
	Setting current	$I_{c2} = I_n \times \dots$	0.2 ~ 1+OFF (OFF means exit)
		Output characteristic	$< I_{c2}$ delay relay making
	Constant time lag (s)		Fixed 60s
Precision		$\pm 10\%$	
Thermal memory(30min, re-set while power off)		Standard+OFF	

4.1.1.6 Imbalance current protection features

Table 6 for reference of technical parameters of imbalance current protection features

Unbalance current of Loss of phase and 3-phase are protected by this imbalance current protection. Here is the expression of imbalance current ratio:

$$\delta = |I - I_{av}| / I_{av} \text{ (} I_{av} \text{ is average of 3-phase)}$$

Imbalance current protection feature is a kind of definite time protection. The setting value of time delay use $t \delta$ mark, protection of imbalance current with the function of alarming without tripping when $t \delta$ in the OFF position.

Table 6: Technical parameters of imbalance current protection features

Setting value of Imbalance current ratio	$\delta =$	40%~100%+OFF (1% interval, OFF means exit)
	Operating or alarm characteristic	$\leq 0.9 \delta$: no tripping
		$> 1.1 \delta$: delay tripping
Setting value of time delay	$T \delta$ (s)	0.1~1s+OFF (OFF means alarming without tripping, 0.1 interval)
Precision		$\pm 10\%$ 40ms

4.1.2 Auxiliary functions

4.1.2.1 Inspection display

This function keeps all lightening devices indicating accurately in order to maintenance good working situation. Chapter 7.2.2.3 shows the details.

4.1.2.2 Test

Tripping and non-tripping are two ways of stimulation test.

1. Stimulation test of tripping: this test is carried out by instantaneous of tripping. There will be trip and action time of devices display, which used for cooperating with breaker to success testing tripping several times by using the test function key after field debugging, periodic-checking and overhauling. Press the red button on the top of the controller panel before making.
2. Stimulation test of no tripping: Checking the protection feature of the controller, there will be results of no trip, current display in turn and delay action time under this test current. By using this test, the whole procession of actual protection or overload monitor identify without complicated calculation of six kinds of overload characteristic curves. Chapter 7.2.3.5 shows the details.

4.1.2.3 Historical fault recording

While faults occur, the controller will record the relative state and data. After fault-reset or power-off actions, the controller still has fault memory that records the historical event. The old data covered when the new occurs, so it is convenient for analysis before the new comes. Details refer to 7.2.3.2

4.1.2.4 Self-diagnosis

Light T on the panel of the controller will flash when self-diagnosis fault occurs. Details refer to 7.2.3.4.

4.1.2.5 Thermal memory

Repeating overload may cause conductor heating up. The controller has thermo-effect (which simulating bimetallic strip's characteristic) after delay tripping because of overload and short-time delay. The thermo-effect energy of overload release completely in 30 minutes after the fault removed, and for short time delay, it releases completely in 15 minutes after fault removed. The delay time will shorten if overload or short time delay reoccurs after re-closing the breaker during this time, so that the circuit and equipment could be protected well. (The thermal memory characteristic of overload monitoring is the same to that of overload protection).

Accumulated thermo-effect eliminated if the controller power-off and then re-power on. This function is defaulted to be closed when leaves factory, if necessary please point out when ordering or set through ST programmer.

4.1.2.6 MCR make-break and overstep tripping (optional)

Make-break and overstep tripping protections are parts of back-up functions, which are optional. They are both instantaneous tripping actions whose tripping value relate to their service breaking and ultimate breaking capacities. Usually, MCR current is 40KA, 60KA, 80KA, overstep tripping current is 50KA, 75KA, 100KA(especially for Type DW40,45,48 breaker, the factory defaults of current values are 40/50KA for Frame I, 60/75KA for Frame II, 80/100KA for Frame III). Fault current signal sends out tripping instruction directly by hardware comparison circuit. MCR make-break protection works only at the moment of making (about 100 ms), while overstep tripping is available all the time.

4.1.2.7 System clock adjustment function (optional)

The controller can be added function of system clock adjustment, to record time and date when the fault generated. This function automatically effectiveness once is chosen. Details of the function of system clock adjustment considering chapter7.2.3.5

4.1.2.8 Signal contact output function (optional)

The controller output 4 groups of signal separately, this function realized by programmer or other special ways. The provided signal contacts output function and output time indicated as table 7.

Defaulted states of the controller's 4 groups signal contacts output function indicated as table 8.

Table 7 : Controller's signal contacts output function and output time

Serial number	Signal contact output function	Signal contact output time
0	No definition	No output
1	Trip and alarm if short circuit fault instantaneous fault	Output when short circuit instantaneous fault trip occurs
2	Trip and alarm if earthling or leakage fault	Outputting when grounding or leakage fault trip occurs
3	Trip and alarm if unbalance current fault	Outputting when unbalanced current fault trip occurs
4	Trip and alarm if short circuit short time delay fault	Outputting when short circuit short delay fault trip occurs
5	Trip and alarm if overload long time delay fault	Outputting when overload long delay fault trip occurs
6	Trip and alarm if fault	Outputting when any fault trip occurs
7	Unoverload output if overload monitor 1	Outputting when overload monitor 1 time over
8	Unoverload output if overload monitor 2	Outputting when overload monitor 2 time over
9	Alarm if system self-diagnose	Outputting when system self-diagnose fault occurs
10(A)	Alarm if power grid in fault state	Outputting at beginning of protection or monitor delay operation

Table 8 : Defaulted function states of 4 group's contacts in controller

Contact number Controller type	Contact 1	Contact 2	Contact 3	Contact 4
Type2M	Overload monitor 1 unoverload output	Overload monitor 2 unoverload output	system self-diagnose fault alarming	fault tripping and alarming
Type2H	Overload monitor 1 unoverload output	Overload monitor 2 unoverload output	Remote breaking	Remote making

Note : Contact 3 and contact 4 for Type 2H controller are fixed just for remote break and remote make

4.1.2.9 Position lock

There are three position locks: "SET", "LOCAL", "REMOTE" on the panel of the controller for Type KST-2H.

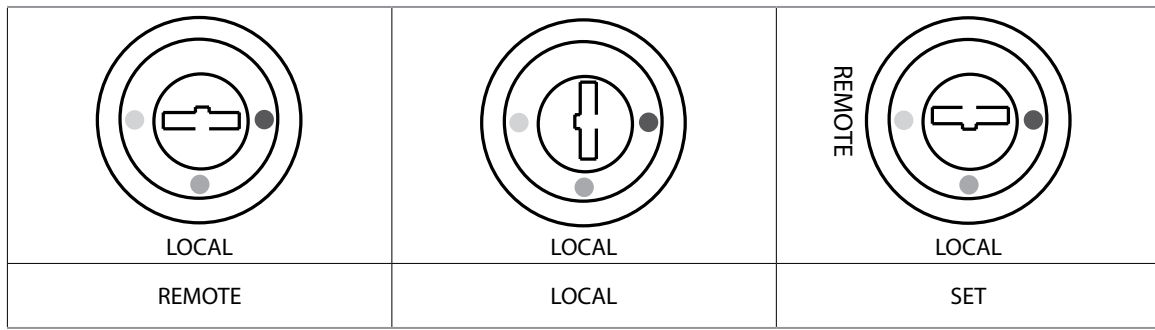

Operation type	Status of position lock		
	SET	LOCAL	REMOTE
Remote control	Not Available	Not Available	Available
Local parameter set	Available	Not Available	Not Available
Local test	Available	Not Available	Not Available
Programmer operation	Available	Available	Available

4.1.2.10 Programming interface function

The controller provides programming interface to communicate with programmer. Users can set internal parameters by programmer, such as: choose type of overload protection characteristic curve, turn on or turn off thermal memory function, set signal contact output function, choose communication protocol function, set communication address, choose communication baud rate, set system clock, set function lock and unlock, choose connection mode of voltage etc. The programmer also has break/close test function, historical data review function, set value copy and other functions.

The telecommunication of the controller stops automatically when the programmer connected to the interface, after the programmer pull out, the telecommunication resumes automatically.

Apply for "ST programmer operating instruction" to get more information.

4.1.2.11 Analogy calculation function of main contact rate of wear

The controller can simulated calculate the main contact wear rate according to the fault current and other data when breaking. The factory-set is 100%; it shows no wear on the main contact. After each breaking operation, the controller will deduct corresponding wear rate, when the value $\leq 60\%$, system will set alarm the self-diagnose signal to inform users taking the maintenance action in time.

After replacing the main contact, users can reset the initial wear rate as 100% by programmer or other special ways.

4.1.2.12 Historical data recording (optional)

The controller can note various historical data of the power grid every 30 minutes, includes date, time, current, voltage, power, frequency, power factor, kilowatt-hour, lasting 3 months. Via programmer interface or telecommunication interface, the relative data review software. In the computer can be read out the information.

5. Time/Current curve

5.1 ACB Operating curves

5.1.1 BA2000-H

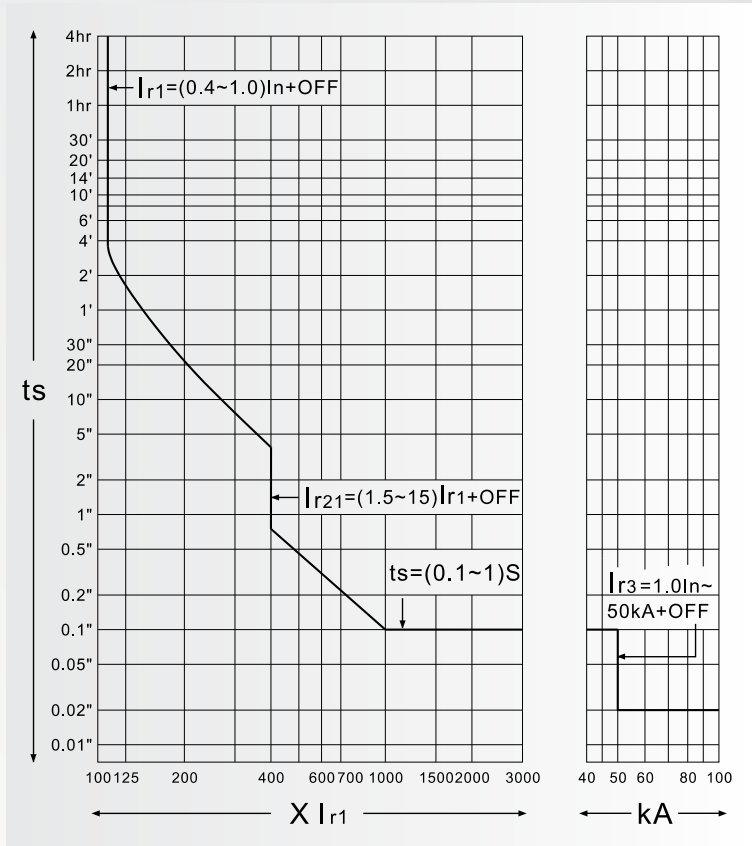

5.1.2 BA3200-H

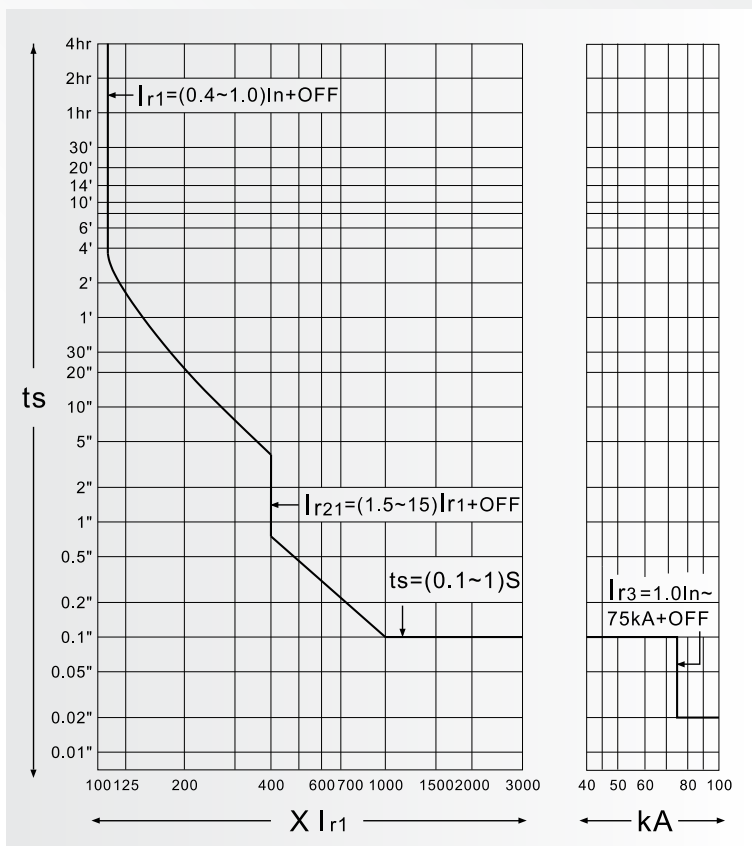

5.1.3 BA4000-H, BA5000-H, BA6300-H

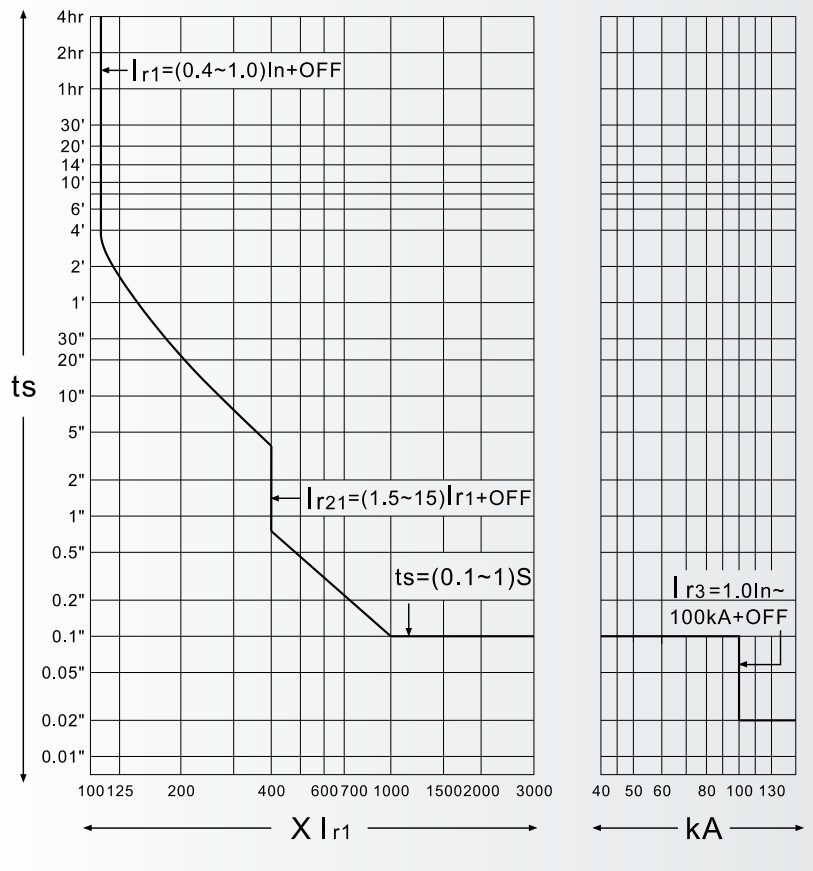

5.2 Controller (IEC 60255 standard)

5.2.1 Overload protection curve

Controller offers six kinds of characteristic curve of overload protection, following the expression:

1. Standard inverse time: $T=0.01396t/(N^{0.02-1})$
2. Quick inverse time: $T=t/(N-1)$
3. Super inverse time (general purpose): $T=3t(N^2-1)$
4. Super inverse time (motor protection): $T=2.95 t \times \ln [N^2/(N^2-1.15)]$
5. High-voltage fuse compatibility: $T=15t/(N^4-1)$
6. Super inverse time 2(general purpose): $T=2.25 t/N^2$
Equal to $T=t \times (1.5 I_r1/I)^2$

Moreover,

T is time value of actual protection delay.

t is setting value of inverse time delay, all setting values of inverse time delay shown in Table 3.

$N=I/I_r1$, it is ratio of actual working current to setting current value of overload long time delay.

Table 9: 6 kinds of inverse time delay setting value of overload protection characteristic curve

Serial No.	Inverse time delay setting value of overload protection characteristic curve: t (s)					
	Delay trip time corresponding to $2I_r1$					Delay trip time corresponding to $1.5I_r1$
	Standard inverse time curve 1	Quick inverse time curve 2	Super inverse time (general purpose) curve 3	Super inverse time (motor protection) curve 4	High-voltage fuse compatibility curve 5	Super inverse time 2 (general purpose) curve 6
1	0.36	1.00	3.32	2.94	0.66	15
2	0.58	1.60	5.32	4.72	1.06	20
3	0.86	2.40	8.00	7.06	1.60	25
4	1.42	4.00	13.32	11.78	2.66	30
5	2.14	6.00	20.00	17.68	4.00	40
6	2.86	8.00	26.66	23.58	5.32	50
7	3.58	10.00	33.32	29.46	6.66	60
8	5.36	13.50	45.00	39.78	9.00	80
9	6.44	18.00	60.00	53.04	12.00	100
10	10.02	28.00	93.32	82.52	18.66	120
11	14.32	40.00	133	117	26.66	160
12	21.48	60.00	200	176	40.00	200
13	28.64	80.00	266	235	53.32	240
14	35.80	100	333	294	66.66	320
15	42.98	120	400	353	80.00	400
16	50.14	140	433	383	86.66	480

Calculate illustration:

Assume the setting conditions of a controller as, Curve 3 is the characteristic curve of overload long time delay protection, I_r1 , t_l are 2000A and 20.00s respectively. Calculate the time of overload long time delay TL when the actual fault current is 3000A.

$$N=I/I_r1=3000/2000=1.5$$

$$TL=3 T_l / (N^2-1) = 3 \times 20 / (1.5 \times 1.5 - 1) = 48s$$

Therefore, here TL is 48s.

5.2.1.1 Standard inverse time : $T=0.01396t/(N^{0.02}-1)$

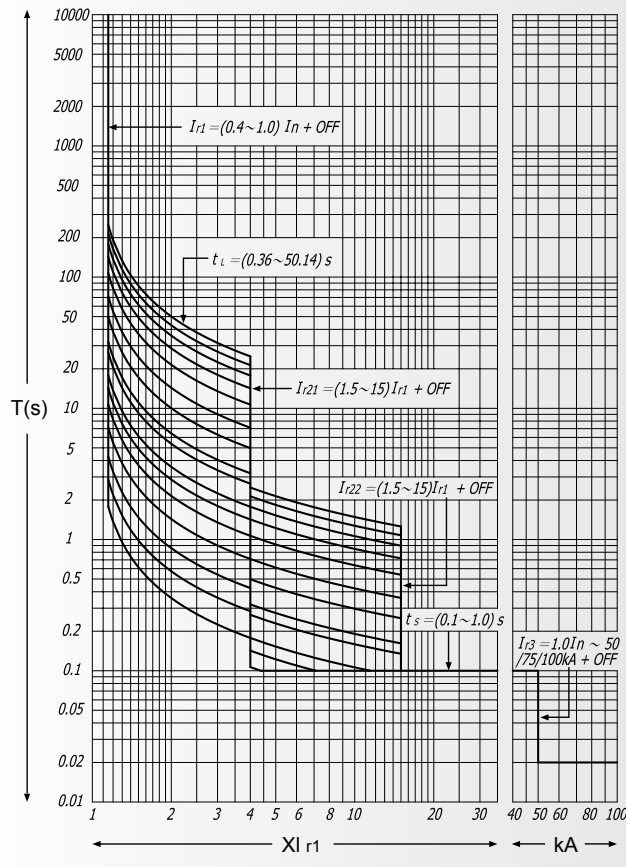

5.2.1.2 Quick inverse time : $T = t / (N-1)$

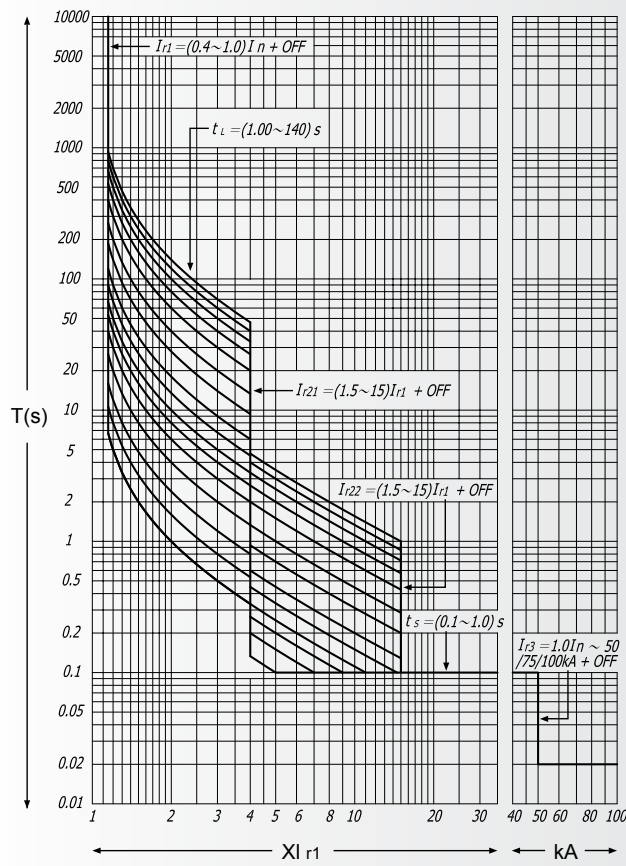

5.2.1.3 Super inverse time (general purpose) : $T=3t / (N^2- 1)$

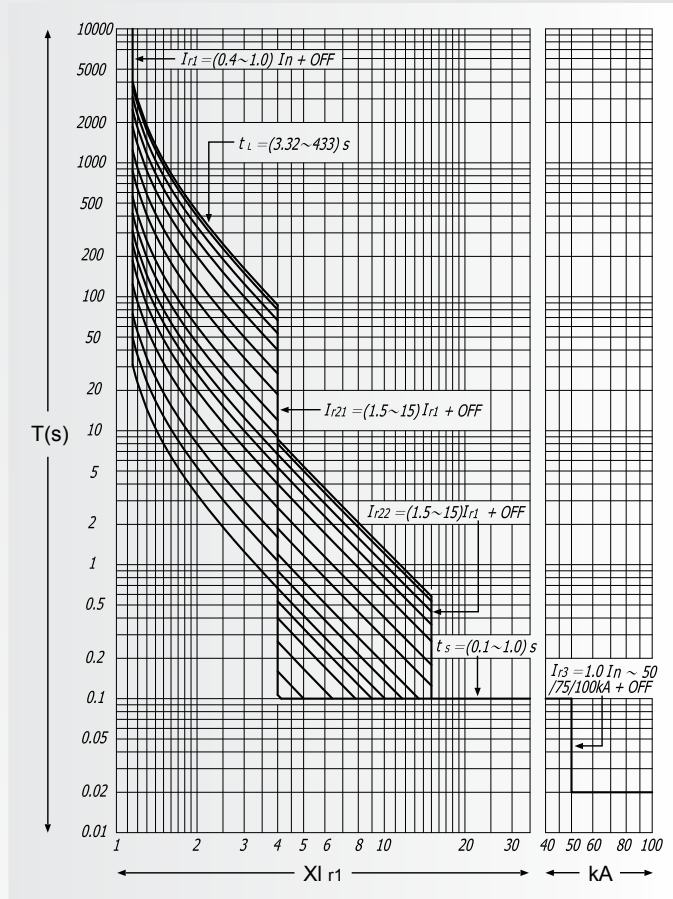

5.2.1.4 Super inverse time (motor protection) : $T=2.95t \times \ln (N^2/(N^2-1.15))$

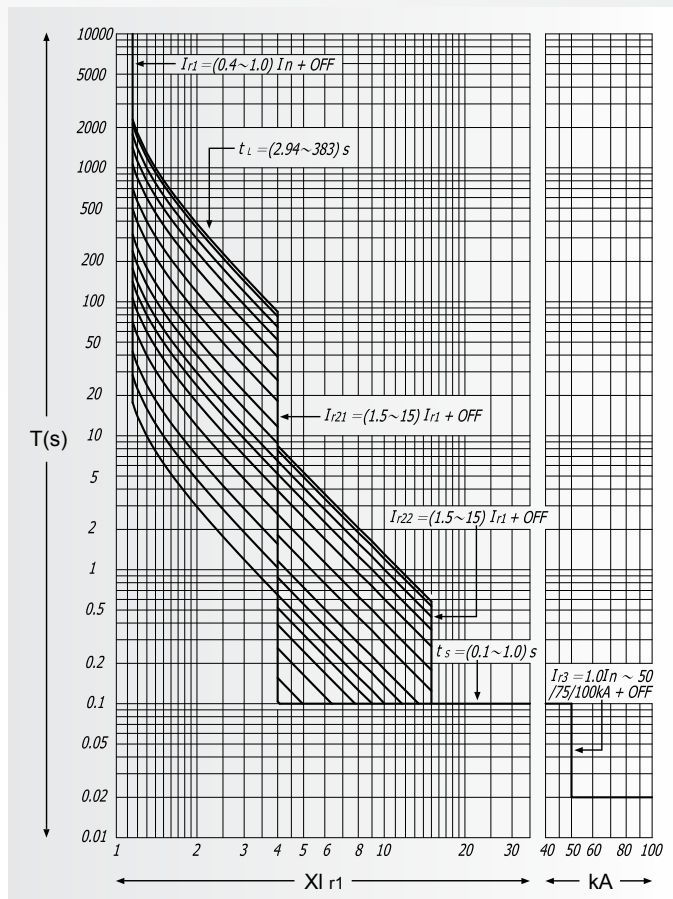

5.2.1.5 High-voltage fuse compatibility : $T = 15t / (N^4 - 1)$

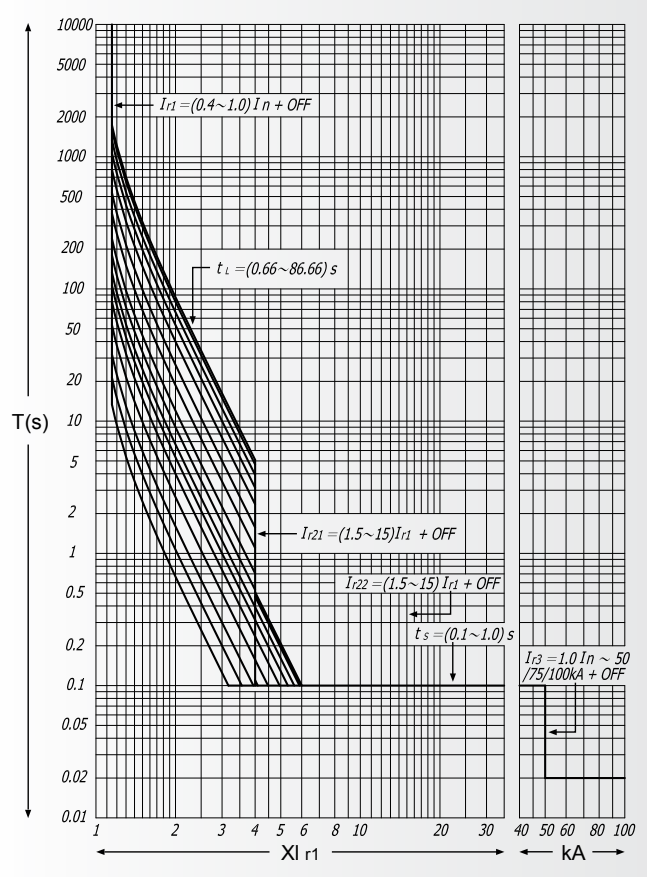

5.2.1.6 Super inverse time 2 (general purpose) : $T = 2.25t / N^2$, $T = t \times (1.5 I_{r1} / I)^2$

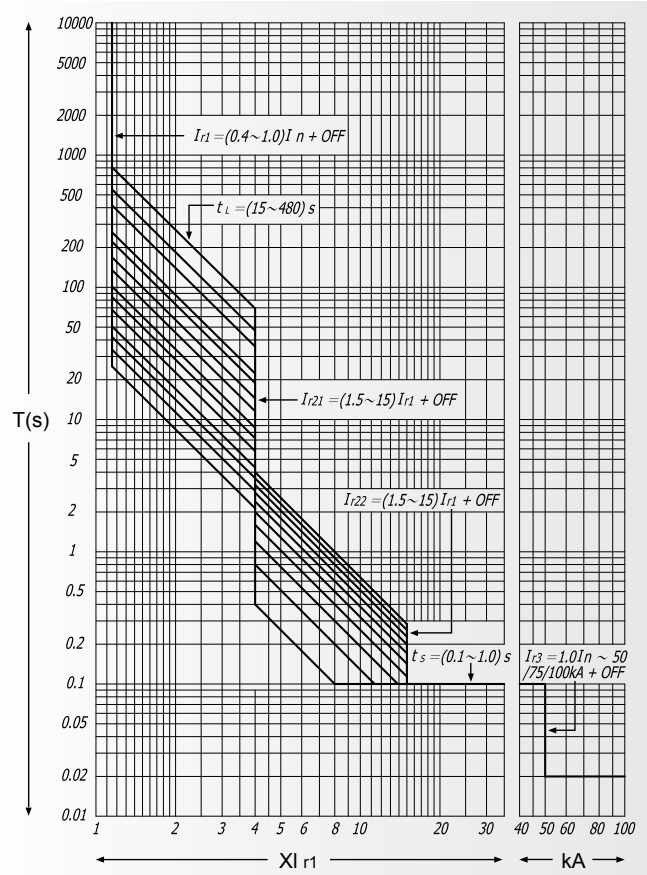

5.2.2 Earth characteristic curve (vector sum mode)

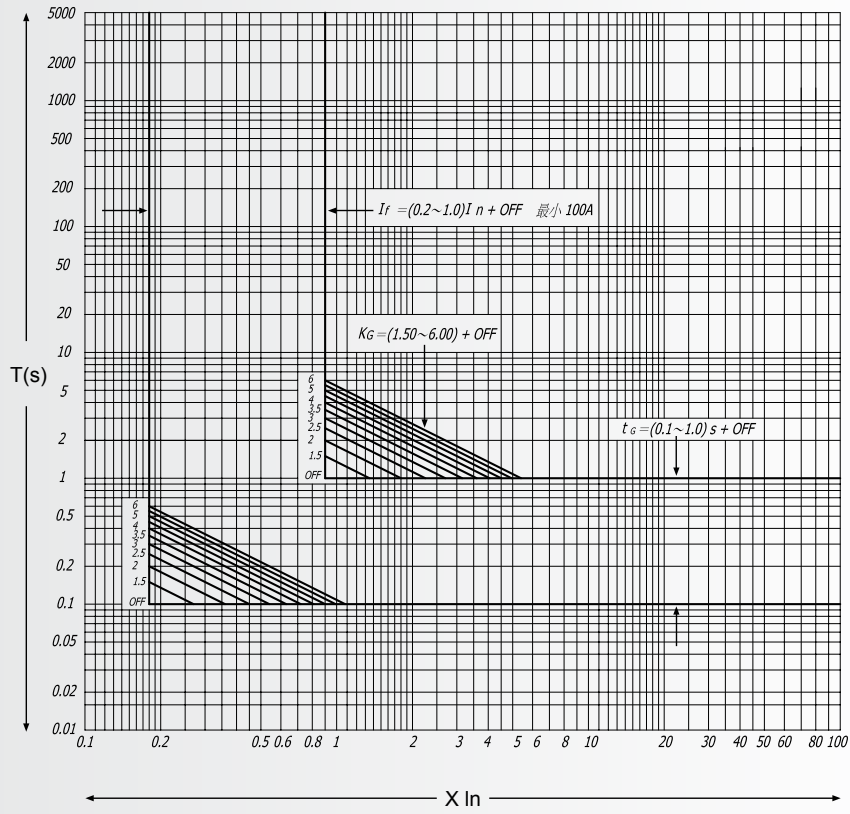

5.2.3 Earth characteristic curve (external transformer mode)

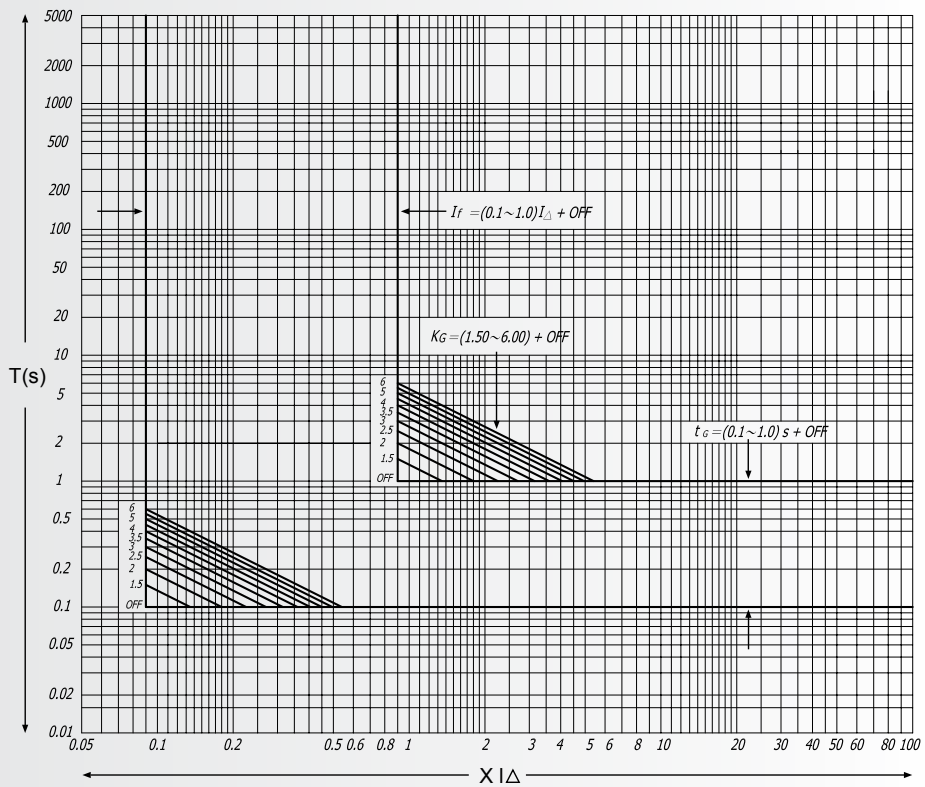

5.2.4 Load monitoring (Mode 1): two load limiting values

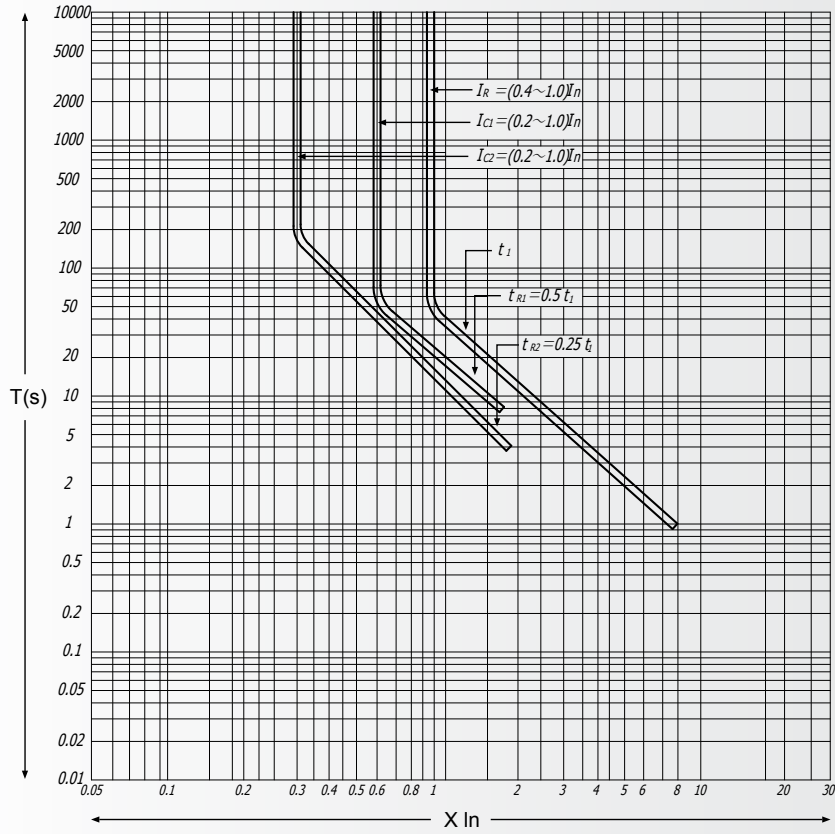

5.2.5 Load monitoring (Mode 2): one is load limiting value, another is load reclosing

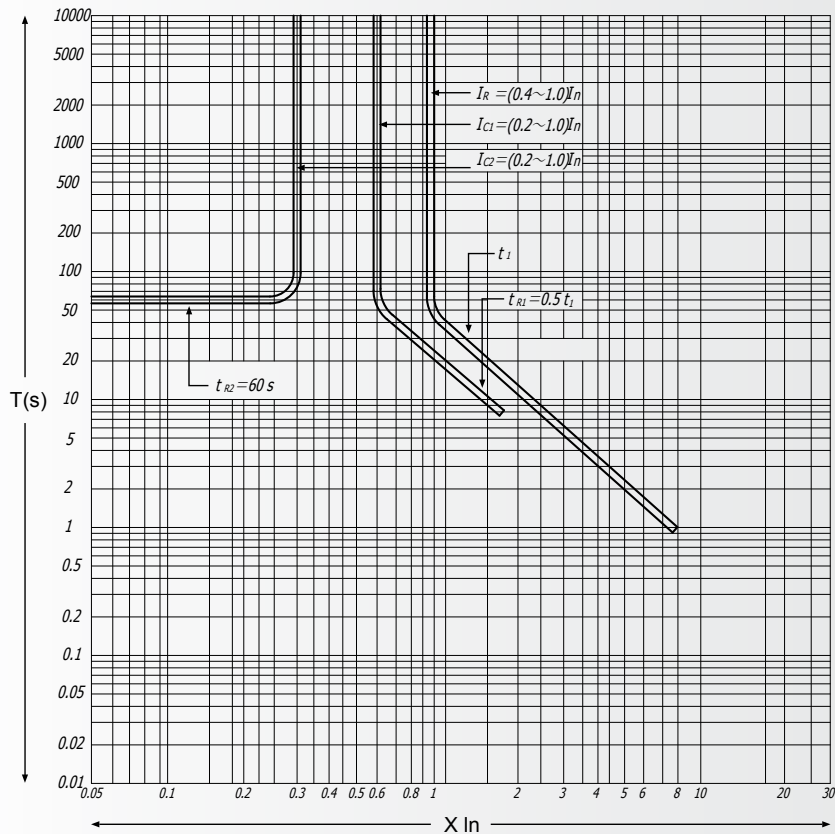

6. Accessories and functions

6.1 Shunt release, Undervoltage release, Motor-driven mechanism, Closing electromagne

Rated voltage	AC		DC	
	220V	380V	110V	220V
Required power Items	220V	380V	110V	220V
Shunt release	24VA	36VA	" — "	24W
Under voltage release	24VA	36VA	" — "	
Motor-driven mechanism	85VA/110VA/150W	85VA/110VA/150W	85W/110W/150W	85 VA /110W
Closing electromagnet	24VA	36VA	" — "	24W

Note : The reliable operating voltage of the shunt release ranges from 70% to 110%, but for the closing electromagnet and the motor-driven mechanism, it ranges from 85% to 110%.

Characteristic of circuit-breaker under-voltage release

Types		Under-voltage delay release	Under-voltage instantaneous release
Operating time of release		1-5s delay	Instant
Operating voltage of release	35 ~ 70%Ue	Break the circuit breaker	
	≤ 35%Ue	the circuit breaker cannot closed	
	≥ 85% ~ 110%Ue	Reliable close the circuit breaker	
Voltage of the power recovers to 85% Ue in 1/2 delay time		No break of circuit breaker	

Note : The precision of the delay time is $\pm 10\%$ °

6.2 Auxiliary contacts

Rated thermal current of auxiliary contact: 6A

Style of auxiliary: 4 normal-open and 4 normal-close, connected as 4 groups of over contacts while contactor group drawing out of the breaker

Usage categories of auxiliary contact : AC-15 、 DC-13.

Rated control power : AC300VA 、 DC60W.

Making and breaking ability in normal working condition.

a. Auxiliary contacts performance in abnormal operation

Type	Model	Power (Pe)	VAC (Ue)	Connection performance				Operation time and frequency W/ input		
				U/Ue	I/Ie	COS θ	T0.95 (ms)	Time in 1 cycle	Time in 1 sec	Time for input (s)
AC	AC-15	300VA	380V	1.1	10	0.3	-	10	6 (OR same as input operation time)	0.05
DC	DC-13	60W	220V	1.1	1.1	-	300			

b. Auxiliary contacts performance in normal operation

Type	Model	Power (Pe)	VAC (Ue)	Connection performance				Break performance			
				U/Ue	I/Ie	COS θ	T0.95 (ms)	U/Ue	I/Ie	COS θ	T0.95 (ms)
AC	AC-15	300VA	380V	1	10	0.3	-	1	10	0.3	-
DC	DC-13	60W	220V	1	1	-	300	1	1	-	300

Note : Life time of Auxiliary contacts is 6,050 times. 6 times of operation cycle is same as main circuit, and the minimum connection time is 0.05 sec which is same as input connection.

6.3 Mechanical interlocking

6.3.1 Superimposed version and side by side version

The interlocking device is installed on the right side of the board of the breaker's drawer seat. The vertical interlocking is completed by the link in lap-fixed breakers. The horizontal interlocking is performed by wire ropes in flat-fixed breakers. If one of the breakers is in close status, the others interlocked cannot be closed. The interlocking device is fixed by customers.

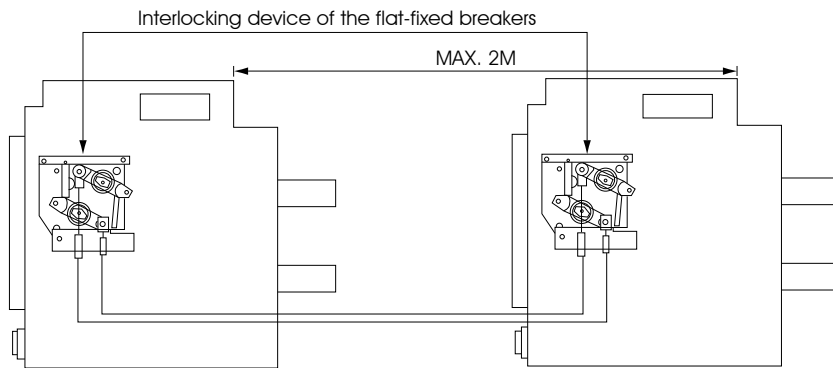
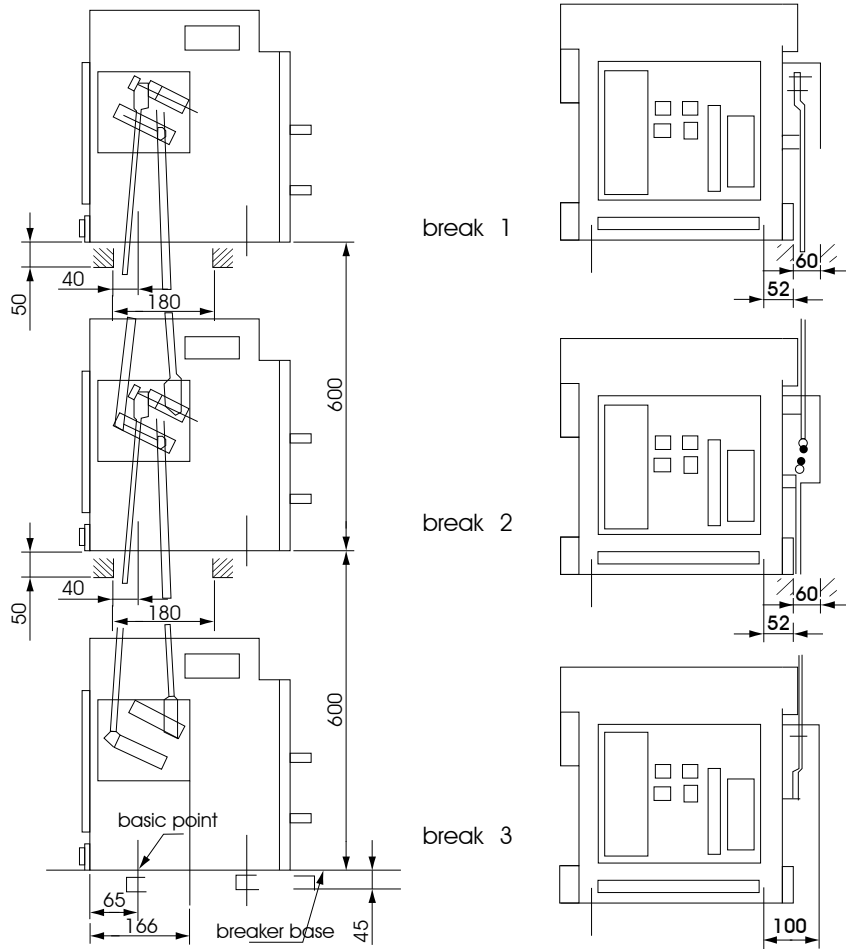

Interlocking device of the lap-fixed breakers (If two breakers of these three need to be interlocked, remove one)

6.3.2 Three-lock-two-key interlocking device

The three-lock-two-key interlocking devices are used on occasions where the breakers are fixed dispersedly. The locks are fixed on the panels of the three breakers separately. When the key had been inserted and rotated to horizontal position, the breaker can carry on make-break operation. The closed breaker will be broken if rotate the key anticlockwise from horizontal to vertical position. At the same time, making operation is forbidden and the key is allowed to take out. It ensures that there are not more than two breakers can be closed at the same time because there are only two keys for three locks.

6.3.3 The compartment door locks

This prevents the compartment door to be opened with the circuit breaker closed. The compartment door lock fixed in the foot right corner of the drawer seat. Following the functions:

- a. The compartment door is allowed to close or open at will if the breaker is at the disconnection position (relative to drawer seat).
- b. Breaker can be pushed in or pulled out to any position between connection and disconnection if the compartment door opens.
- c. Breaker will be locked once the door is closed after the breaker leaving the disconnection position

6.3.4 Other interlock devices

6.3.4.1 Breaking lock

The structure of the breaking lock is the same as the three-lock-two-key. However, there is only one key for one lock. If the breaking button of the breaker is locked, the making button will be disabled.

6.3.4.2 Button locking device

It is used for making button and breaking button of the breaker. These two buttons cannot be used unless unlock the breaker, and the breaker keeps its old state.

6.3.4.3 Padlock device

It is used in drawer type breaker and it is possible to lock the disconnection, connection, test positions.

6.3.4.4 Padlock

The function of it is the same as padlock device. It is used for drawer type breaker and it is possible to lock the disconnection, connection, test position.

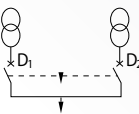
wiring	possible cause	
	D ₁	D ₂
2×breaker lock	0	0
	0	1
	1	0

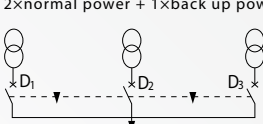
wiring	possible cause		
	D ₁	D ₂	D ₃
3×breaker lock	0	0	0
2×normal power + 1×back up power	1	0	0
	0	0	1
	1	1	0
	0	1	0

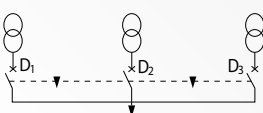
wiring	possible cause		
	D ₁	D ₂	D ₃
3×breaker lock	0	0	0
3×normal power for one breaker	1	0	0
	0	1	0
	0	0	1
	0	0	1

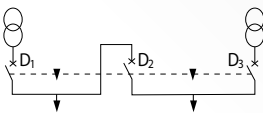
wiring	possible cause		
	D ₁	D ₂	D ₃
3×breaker lock	0	0	0
double power and one switch	1	0	0
	0	1	0
	0	0	1
	1	1	0
	0	1	1
	1	0	1

7. Secondary connection diagram

Connection of controller and breaker

The code of leading wire and the plug socket must be corresponded. Details are indicated as following:

7.1 KST45-M series intelligent controller

7.1.1 wiring

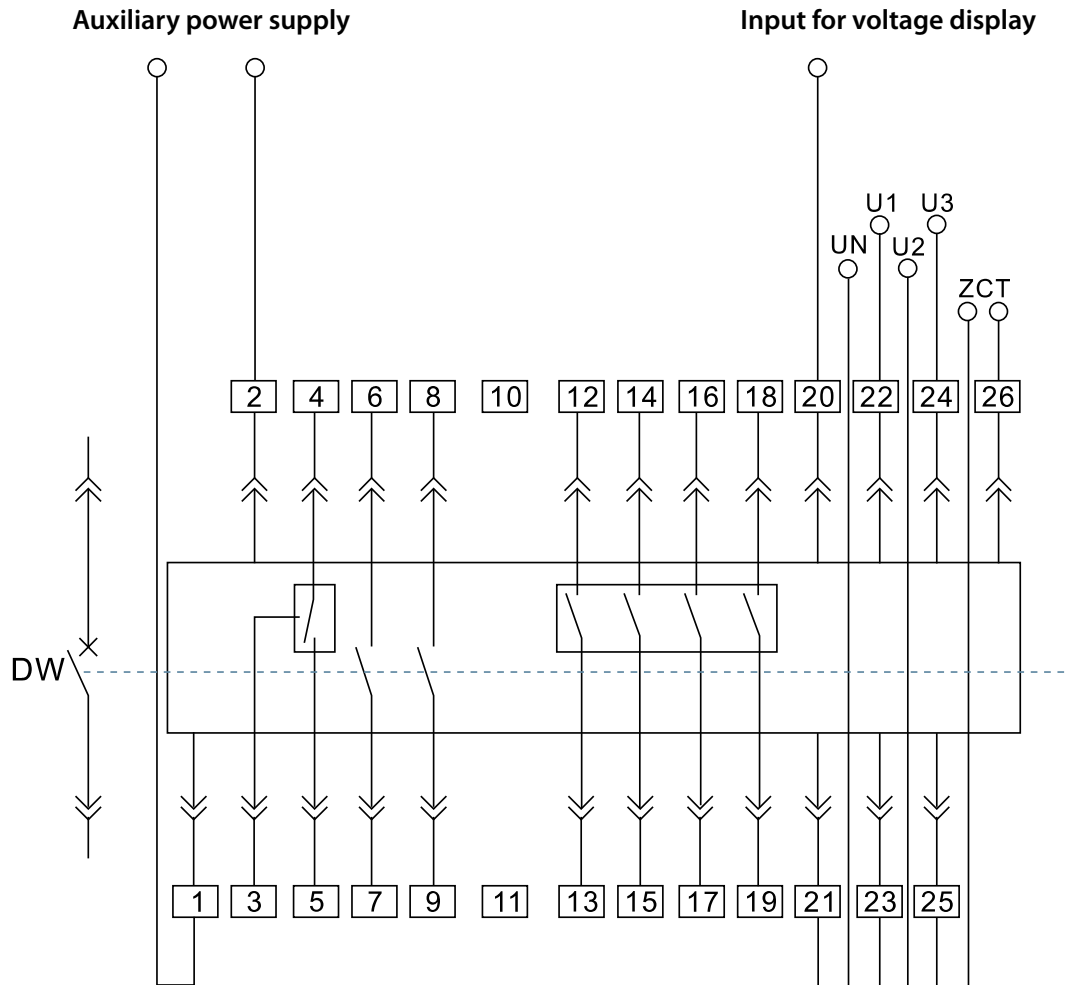

Functions of leading wires:

Wire 1#, 2#: auxiliary power supply input.

Wire 3#, 4# and 5#: output terminal of fault trip contact (4# is public terminal). Capacity: AC 380V/16A

Wire 6#, 7#: output terminal of the first ACB state secondary contact. Capacity: AC 380V/16A

Wire 8#, 9#: output terminal of the second ACB state secondary contact. Capacity: AC 380V/16A

Wire 12#, 13#: output of controller's first group signal contacts.

Wire 14#, 15#: output of controller's second group signal contacts.

Wire 16#, 17#: output of controller's third group signal contacts.

Wire 18#, 19#: output of controller's fourth group signal contacts. Capacity: AC 240V/5A, DC 24V/1A

Wire 20#: protective earth wire.

Wire 21#, 22#, 23#, and 24#: input of voltage display (it is available when it includes functional meter).

Wire 25#, 26#: input of outer transformer (during leakage protection).

7.1.2 KST45-M series intelligent controller

(1) Wiring diagram for 4 normal open and 4 normal close

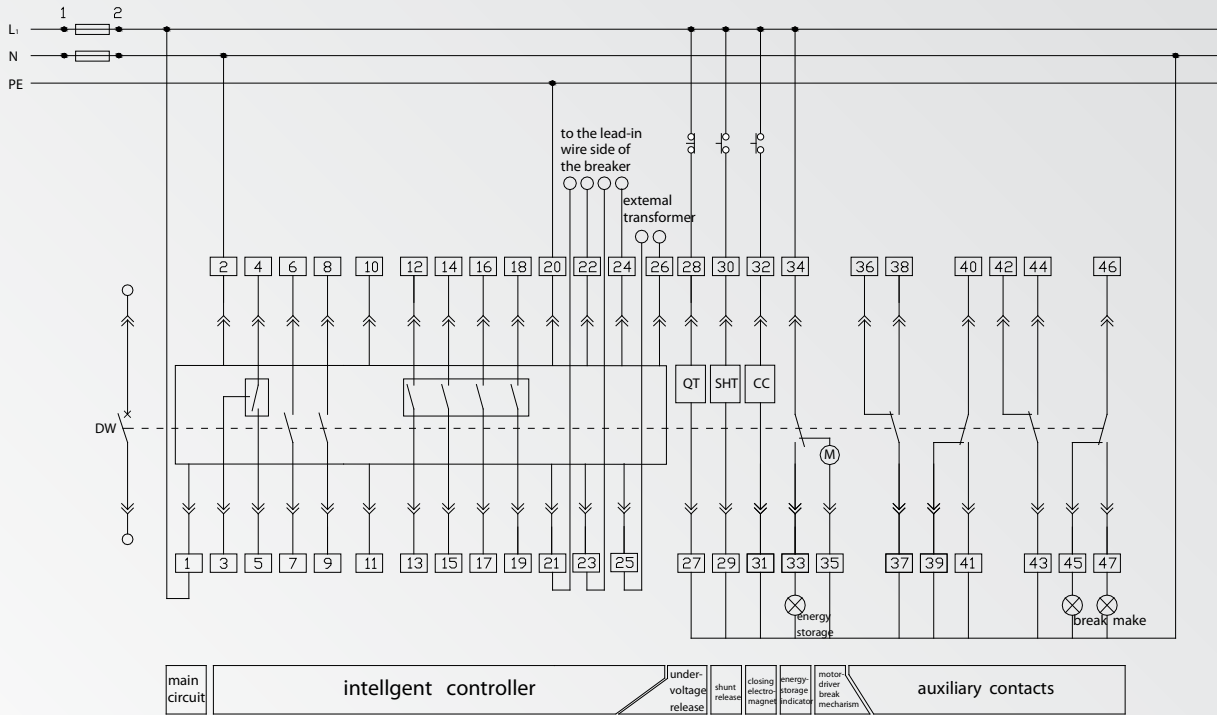

(2) Wiring diagram for 5 normal open and 5 normal close

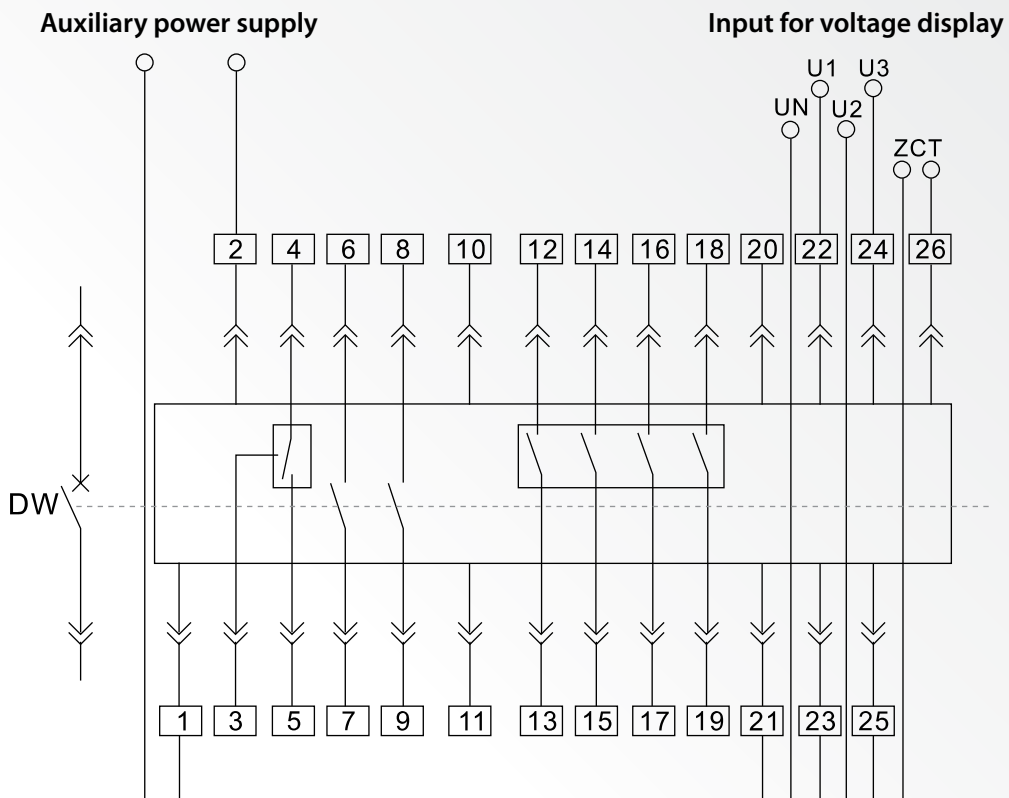

7.2 Electric Controller

7.2.1 M type controller wiring

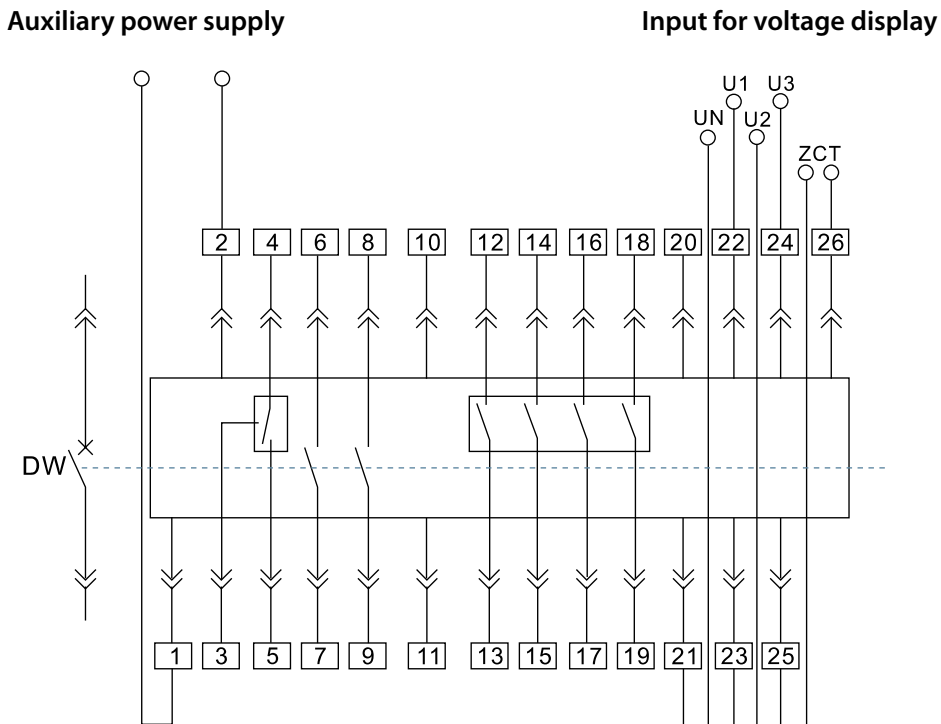

Functions of leading wires:

Wire 1#, 2#: Auxiliary power supply input, and wire 1# is + voltage in DC input.

Wire 3#, 4# and 5#: Output terminal of fault trip contact (4# is public terminal). The terminal capacity is AC 380V/16A.

Wire 6#, 7#: Output terminal of the first ACB state secondary contact. The terminal capacity is AC 380V/16A.

Wire 8#, 9#: Output terminal of the second ACB state secondary contact. The terminal capacity is AC 380V/16A.

Wire 10#, 11#: RS485 communication interface leading-out-wire A, B.

Wire 12#, 13#: Output of controller's first group signal contacts. The terminal capacity is AC 240V/5A, DC 24V/7A.

Wire 14#, 15#: Output of controller's second group signal contacts. The terminal capacity is AC 240V/5A, DC 24V/7A.

Wire 16#, 17#: Output of controller's third group signal contacts. The terminal capacity is AC 240V/5A, DC 24V/7A.

Wire 18#, 19#: Output of controller's fourth group signal contacts. The terminal capacity is AC 240V/5A, DC 24V/7A.

Wire 20#: Protective earth wire.

Wire 21#, 22#, 23#, and 24#: Input of voltage display (it is available when it includes functional meter). Note: Following the wiring sequence.

Wire 25#, 26#: Input of outer transformer (during leakage protection).

7.2.2 H type controller wiring

H type controller wiring is same as M type, please refer to 7.2.1 wiring .

7.2.3 H series intelligent controller

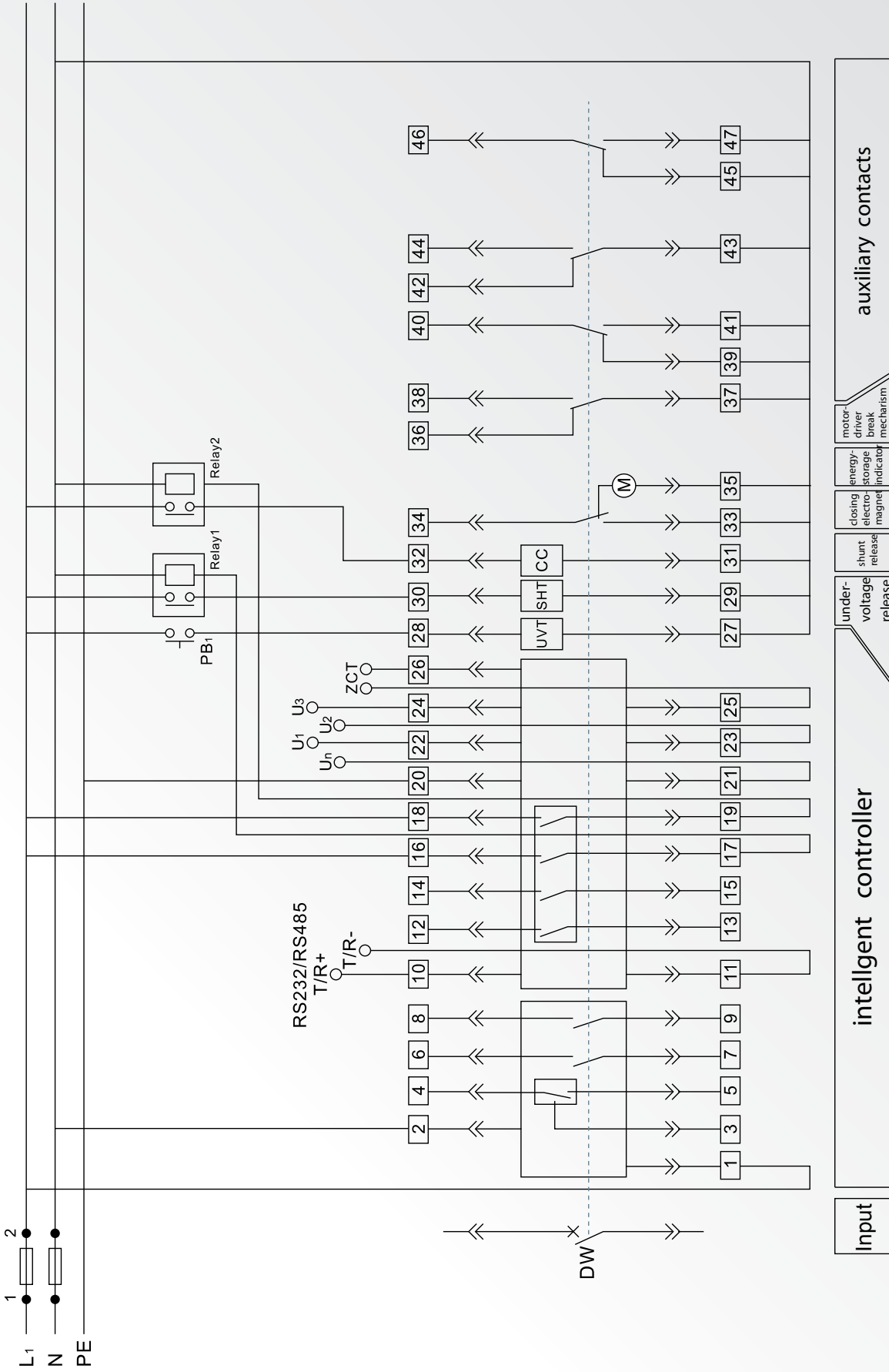

Note: If the controller w/ DC input, the controller required for additional power modular. Also, the #1 and #2 can not connect any power.

7.3 ATS

ACB Controller panel wiring

M : Motor
(34,35)

NLS : Standard Input side (Normal power) auxiliary connection
(39,40,41 / 36,37,38)

ELS : Emergency Input side (Optional power) auxiliary connection
(39,40,41 / 36,37,38)

CC : Closing electromagnet
(31,32)

SHT : Shunt release
(29,30)

UVT : Under voltage release
(27,28)

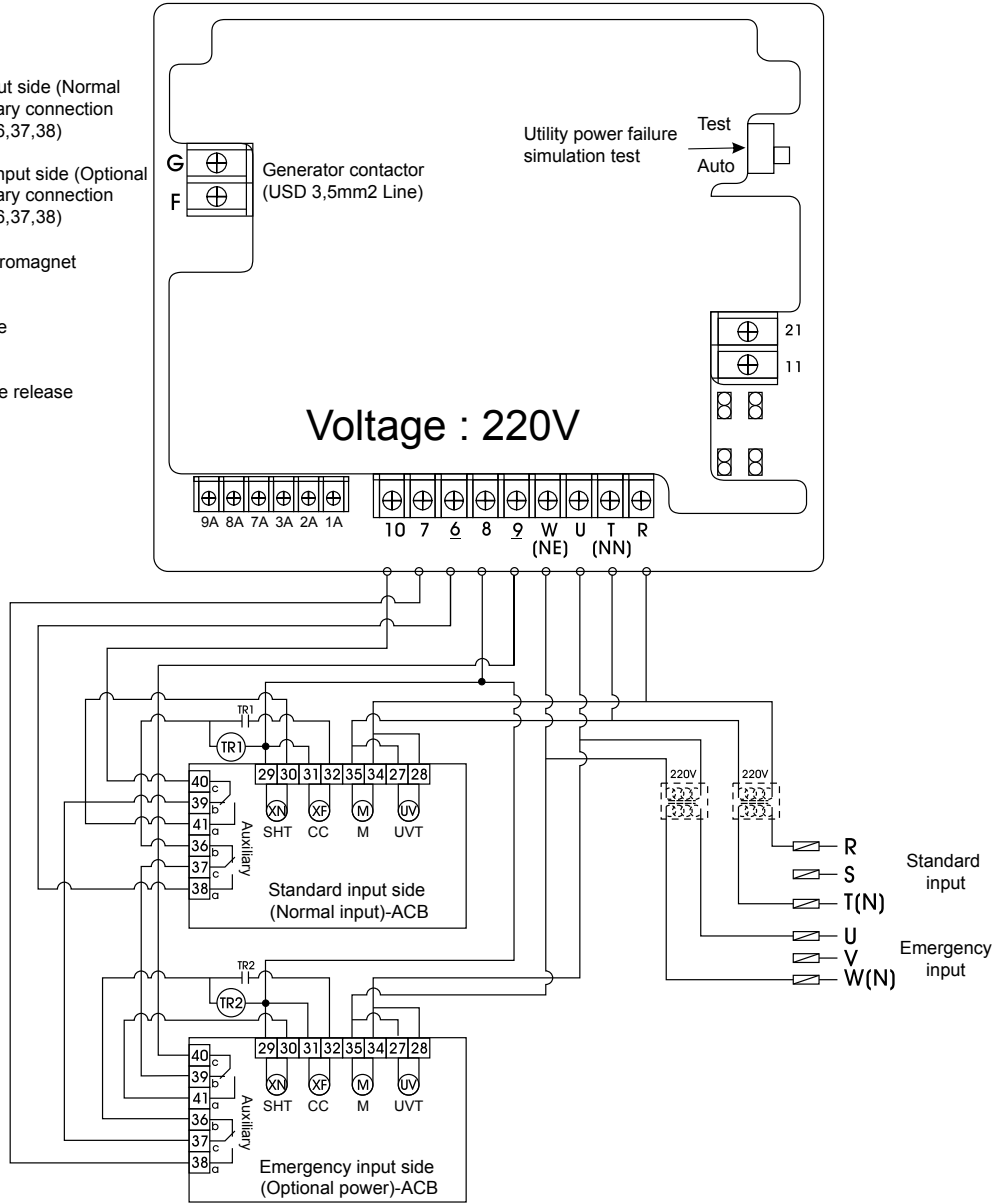

8. Outline and installing dimension

8.1 Withdrawable circuit-breaker

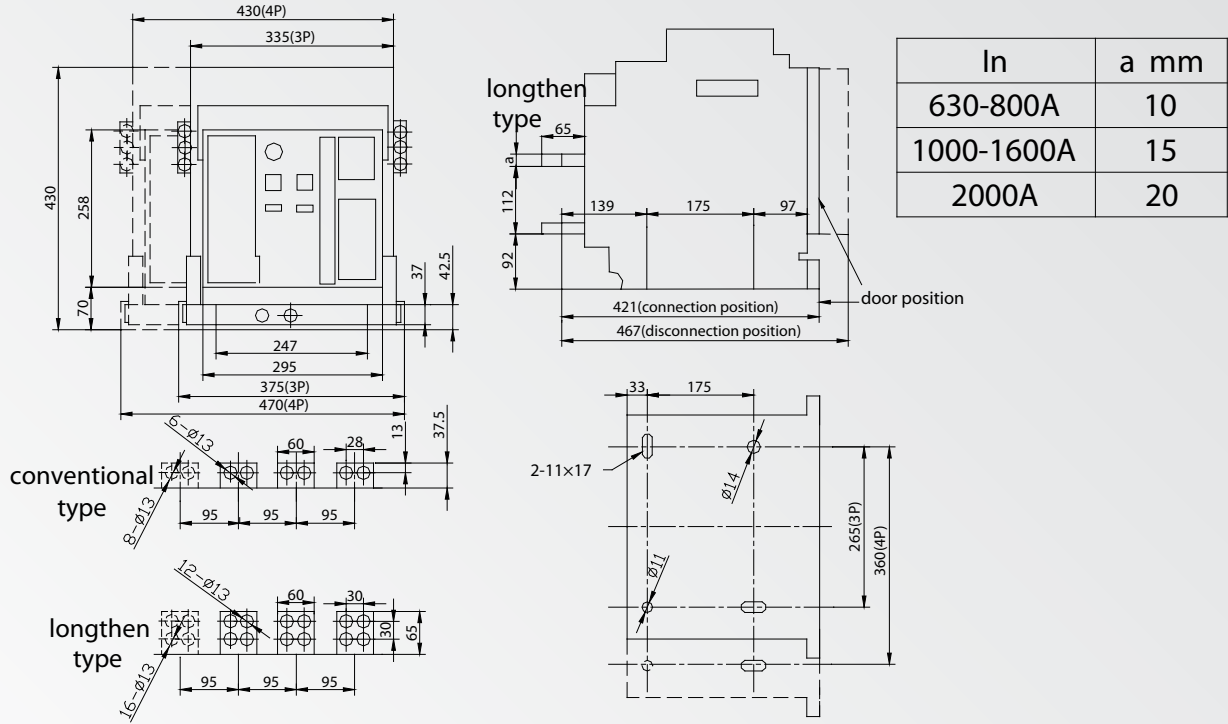

Overall dimension of drawer type breaker (BA-2000)

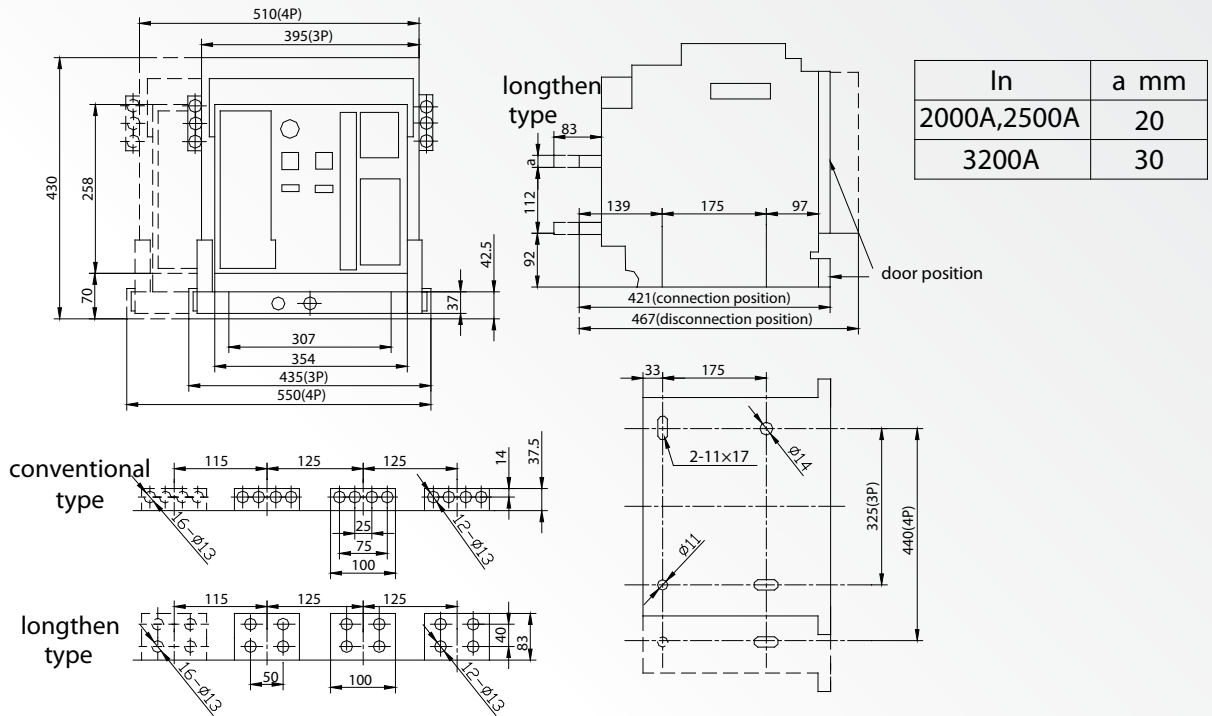

Overall dimension of drawer type breaker (BA-3200)

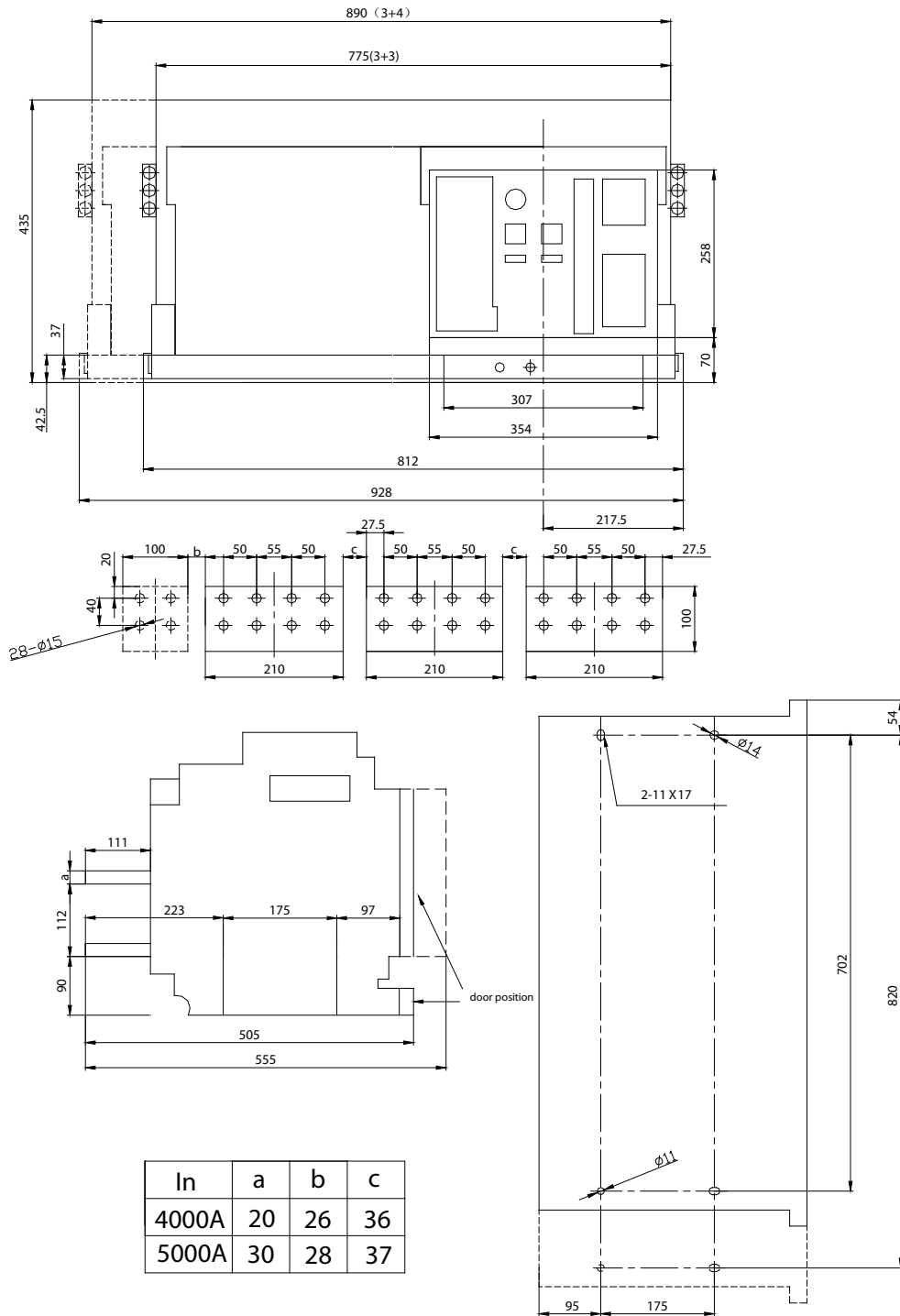

Overall dimension of drawer type breaker (BA-6300)

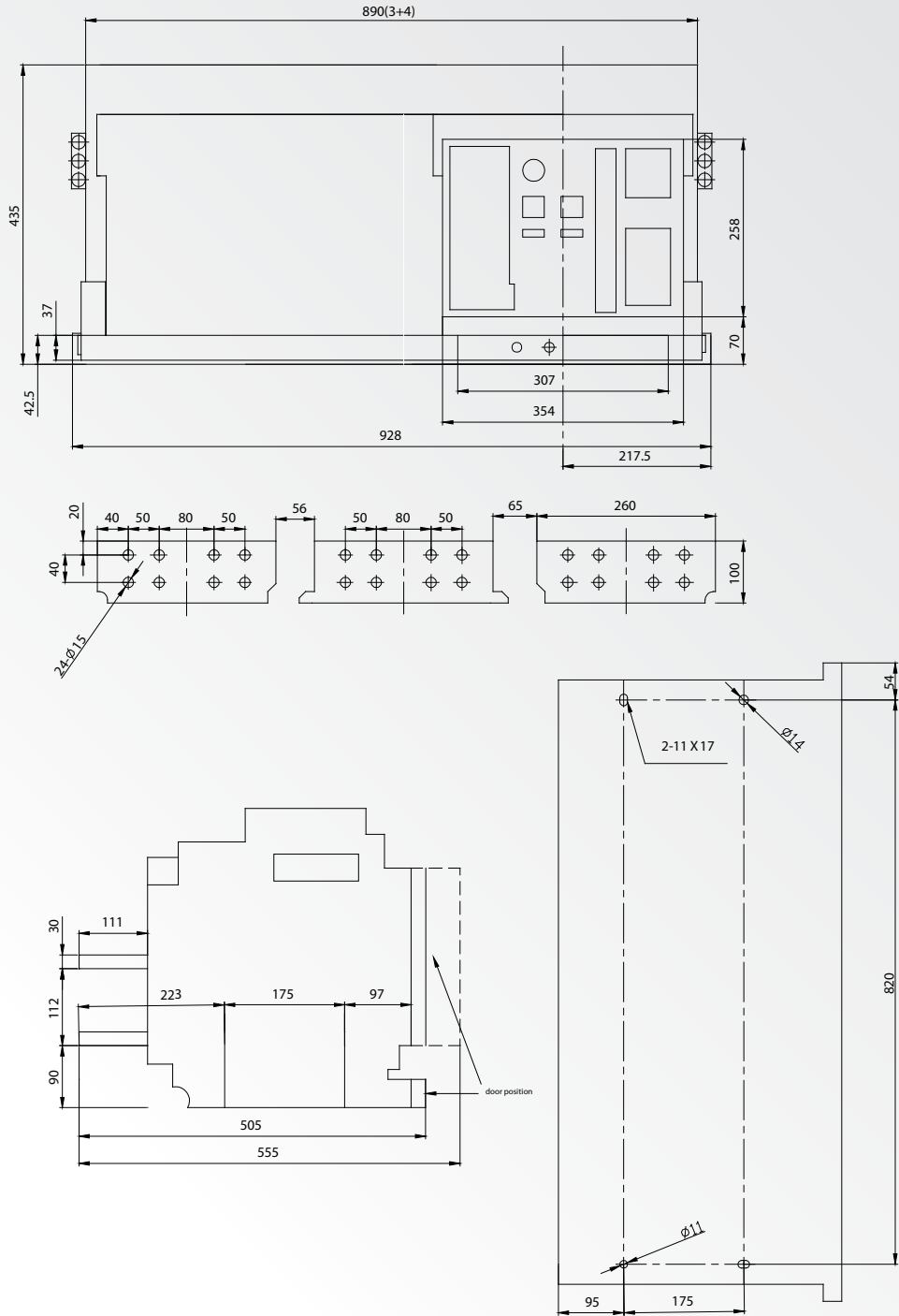

Overall dimension of drawer type breaker (BA-6300)

8.2 Fixed circuit breaker

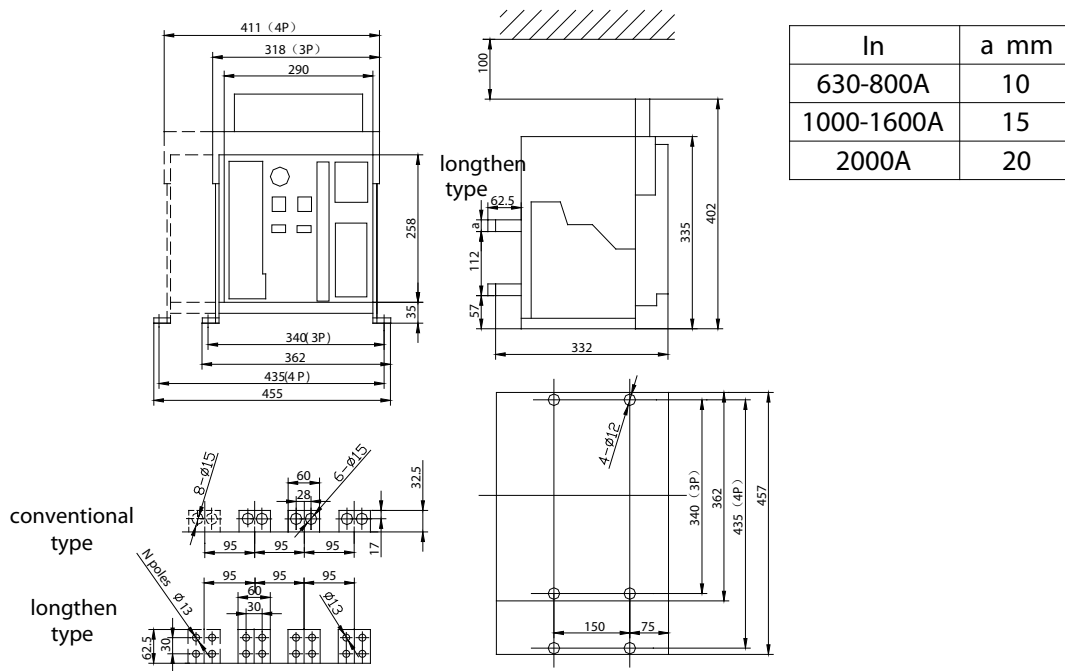

Overall dimension of fixed type breaker (BA-2000)

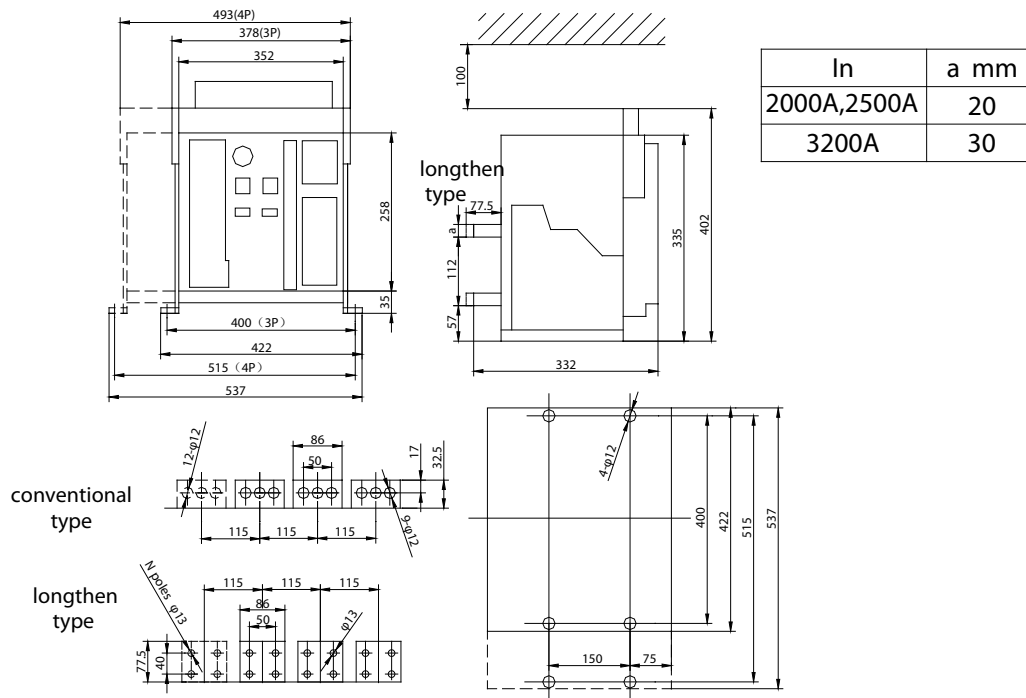

Overall dimension of fixed type breaker (BA-3200)

8.3 Dimension of drilling compartment door and installment pitch of holes

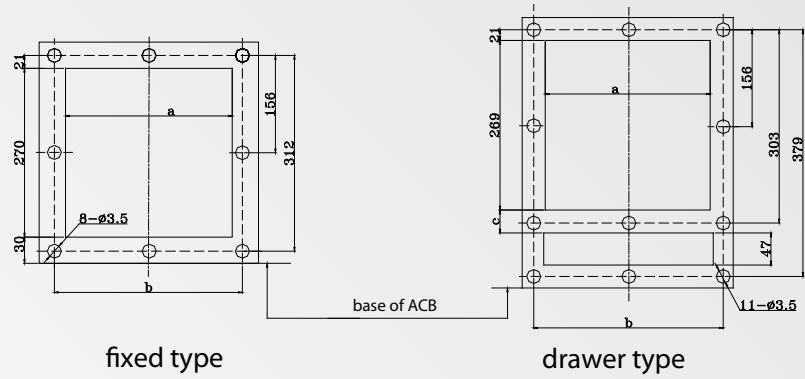

Inm/A	a mm	b mm
2000	303	345
3200	364	406

Inm/A	a mm	b mm	c mm
2000	301	345	20
3200	364	406	21

Dimension of drilling panel

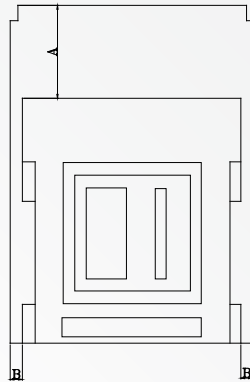

drawer type

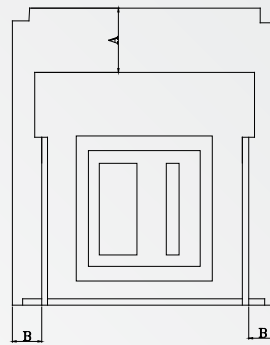

fixed type

	to isolator		to metal	
	A	B	A	B
drawer type	0	0	0	0
fixed type	100	30	100	70

9. Mounting, usage and maintenance

9.1 Mounting

- (1) Identify that whether the specification of the breaker conforms to requirements or not before installation.
- (2) Checking the insulation resistance with 500V megger, Resistance should not be less than 10 M when the surrounding medium temperature is $20^{\circ}\text{C} \pm 5^{\circ}\text{C}$ and relative humidity is 50%-70%, otherwise has it drying until insulation resistance conforms to requirements.
- (3) The base of the breaker should be installed horizontally and fix by M10 screws.
- (4) Breaker should have reliable earth fault protection and earthing point should be marked obviously. Fixed type breaker should conform to the rules of the safe distance strictly.
- (5) After installation and connection according to the related wiring diagram, the breaker should be operated as follows (the indication of the drawer seat is "test" for drawer type breaker) before circuit power up.
 - a. Checking that whether the acting voltage of the under-voltage release and the shunt release match that of the closing electromagnet and motor-driven mechanism (breaker can not be operated unless under-voltage release is closed)
 - b. "Energy-storage" will be indicated and "click" will be heard after cradling the handle seven times up and down, which is the end of energy-storage. Press making button or switch on the closing electromagnet to close breaker reliably. Cradling again can restore energy. (In the condition of the controller's re-setting, refer to picture15, number1)
 - c. "Energy-storage" will be indicated and "click" should be heard after switching on the power of motor-driven energy-storage mechanism and motor, which is energy-storage finished. The motor is power-off automatically at that moment. Press making button or switch on closing electromagnet to close breaker reliably.
 - d. When the breaker is closed, whatever the under voltage release or the shunt release or the breaking button on the veil, all tripping test of those intelligent release tests can break the breaker.

9.2 Usage of intelligent controller

9.2.1 Panel schematic diagram

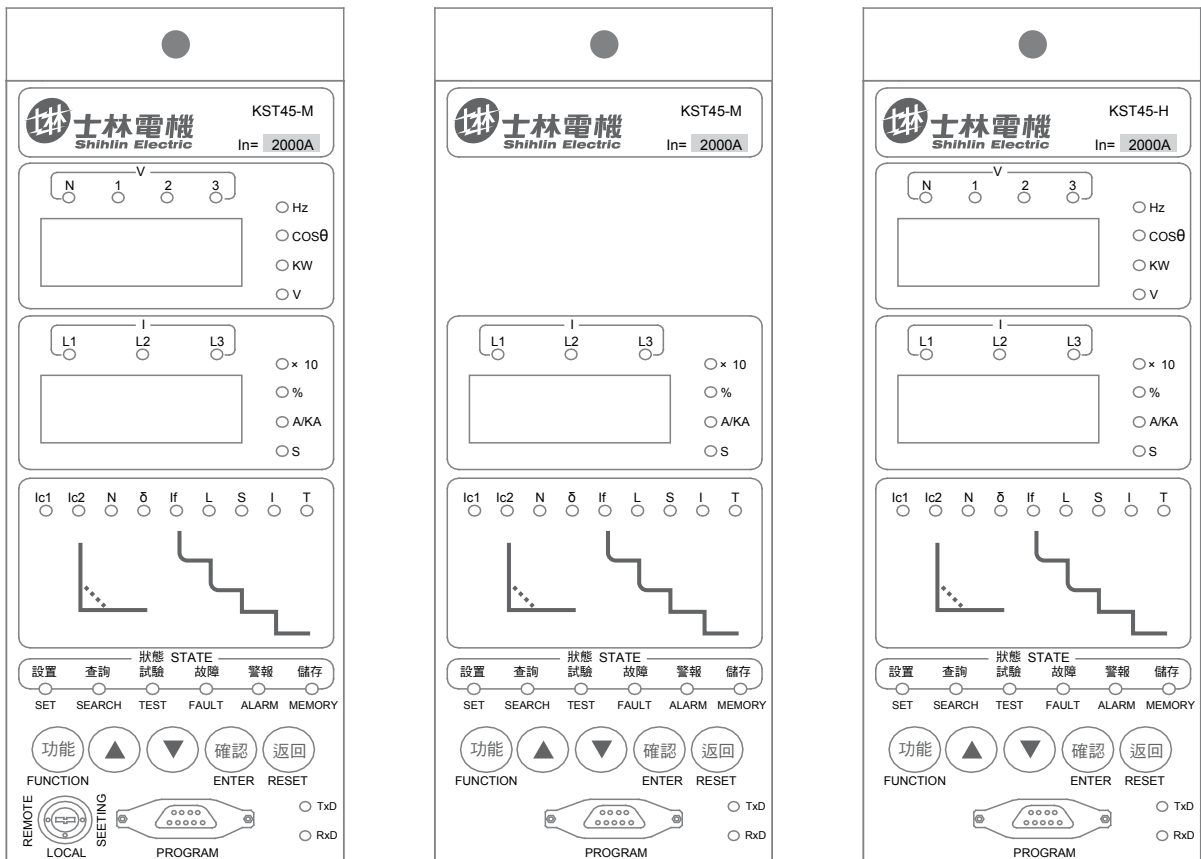

M style with function window

M style without function window

H style

9.2.2 Contents of Display

9.2.2.1 Summary

The panel of type ST-2M or type H controller can be divided into four parts: function display window, ammeter display window, protection category indication window and running state indication window. Check diagram for the details.

The measure parameters can be displayed in function display windows including: voltages of three-phase, activepower, power factor, frequency, etc.

The display windows of the ammeter, the protection category and the working state are used together. They display different contents in different state, which mainly include current and auxiliary parameters, setting value, fault, test parameters, self-diagnosis, fault query and so on.

9.2.2.2 Display the working status

The controller can be in the following states: reset state, parameter set state, fault search state, simulation test state, fault alarm state, fault display state, self-diagnose state, and parameter memory state. The differentiation of different states is realized through the association of the indicating lamps, details are as following:

- ① Reset state: All status indicating lamps are off; the controller is in no button press and no fault state, every parameter is in loop indicating state.

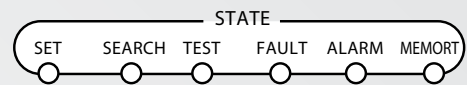

- ② Parameters set state: In this state, controller can modify the setting values of each section protection. The lamps are indicated in right figure.

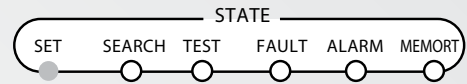

- ③ Fault search state: In this state, controller can search last fault record parameters. The lamps are indicated in right figure

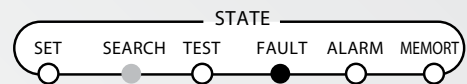

- ④ Simulation test state: in this state, the controller can simulate instantaneous trip and no trip test, the lamps are indicated in right figure

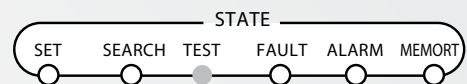

- ⑤ Fault alarming state: In this state, the controller has already found some power grid parameters over the set value, the protection or monitor begin to delay; at this moment, indicating lamps in protection types indicating region will point out types of the fault. The lamps are indicated in right figure.

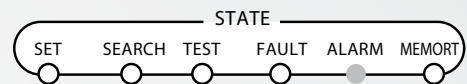

- ⑥ Fault display state: In this state, the controller has already in fault tripping state, protection types indicating region will point out the type of the fault, the lamps are indicated in right figure.

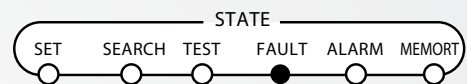

- ⑦ Self-diagnose state: In this state, the controller has already found the self-diagnose fault. The lamps are indicated in right figure.

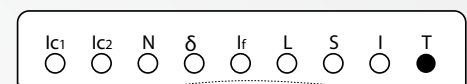

- ⑧ Parameter memory state: In this state, the controller is memorizing the parameter that has already been set; the lamps are indicated in right figure.



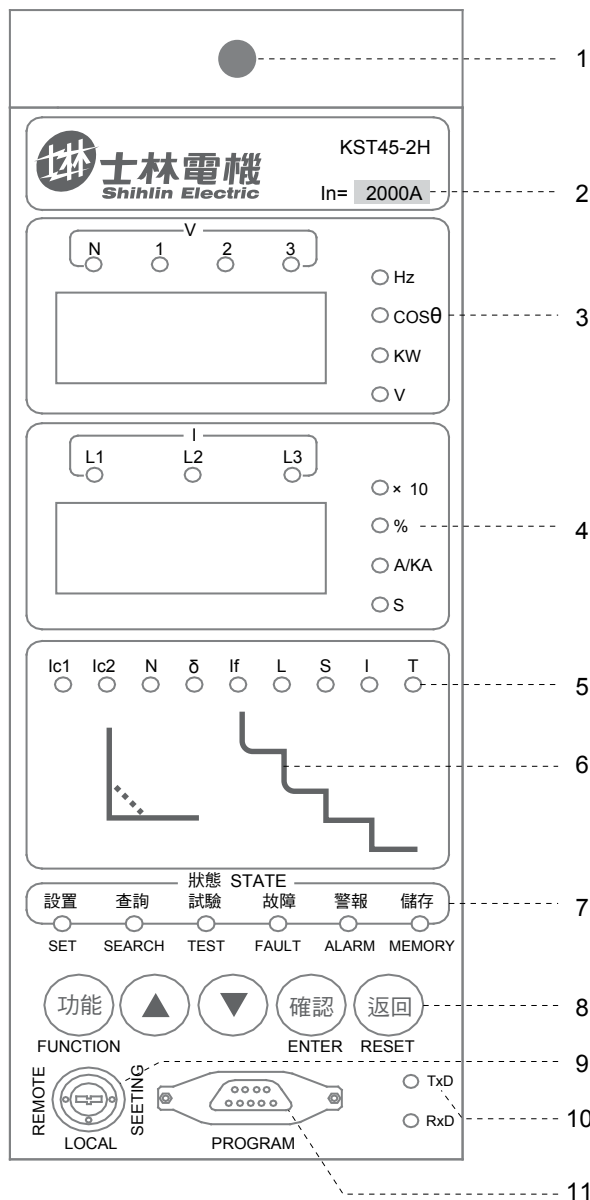

1. Mechanical reset button
2. Rated current indicator
3. Function window
4. Ammeter window
5. Protection category indicator
6. Protection characteristic curves
7. Status indicator
8. Function key
9. Position lock
10. Communication indicator
11. Programming interface

9.2.2.3 Lightning devices display checking

While the controller in reset state without no-self-diagnosis fault ("T") is not light, press return button followed with 6 times of identify button, all lightning devices are shining after several minutes. To press return button or a minute later after lighting, it will back in reset state.

9.2.2.4 Functional window display

Functional window display is the same in any state, includes 2 display modes:

1. Reset state display: In reset state, the window can display three line voltages (U_{AB}, U_{BC}, U_{CA}), three phase voltages (U_A, U_B, U_C), power, power factor, active kilo-watt hour (only after choosing historical data recording function) in loop state.
2. Manual selection display

In reset state, press "▲" or "▼" to manual selection display above parameters; each press can change a displayed parameter, press "RETURN" to quit the state of manual selection display; System will return to reset state automatically if there is no operation in 5 minutes.

The contents indicated in the functional window are explained as follows:

- ① When only the indicating lamp "kW" is on, displayed value is power, the unit is kW. As indicated in right figure, the power is 80 kW. When the lamp "kW" is flashing, it is active kilo-watt hour.

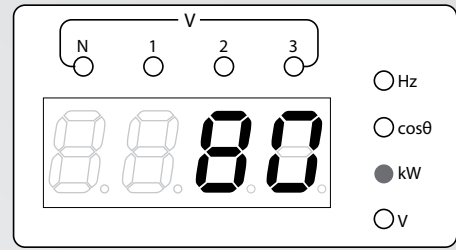

- ② When only the indicating lamp "COS Φ" is on, displayed value is power factor. As indicated in right figure, the power factor is 1.00.

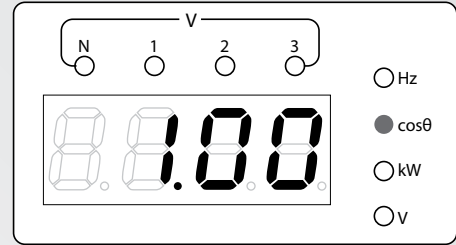

- ③ Just only the indicating lamp "Hz" is on, the displayed value is frequency, the unit is Hz. As indicated in right figure, the frequency is 50.08Hz

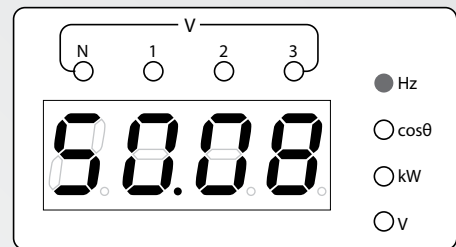

- ④ When both indicating lamps "1" and "V" are on, the displayed value is the line voltage UAB between phase A and phase B; when both indicating lamps "2" and "V" are on, the displayed value is the line voltage UBC between phase B and phase C; When both indicating lamps "3" and "V" are on, the displayed value is the line voltage UCA between phase C and phase A; the unit is V. As indicated in right figure, the line voltage between phase C and phase A is 380V.

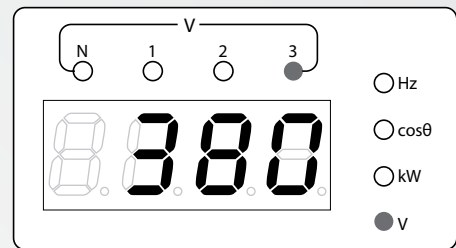

- ⑤ When indicating lamps "1", "N" and "V" are on, the displayed value is phase A's voltage UA; When indicating lamps "2", "N" and "V" are on, the displayed value is phase B's voltage UB; When indicating lamps "3", "N" and "V" are on, the displayed value is phase C's voltage UC; the unit is V. As indicated in right figure, the phase A's voltage is 220V.

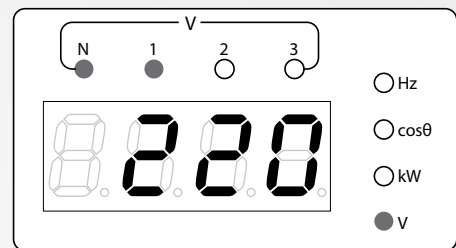

9.2.2.5 The current meter window display

The current meter window display is different in different states, reset state display, manual selection display, auto selection display, fault operation display are indicated as following:

1. Reset state display:

In reset state, the window is displayed three-phase currents through a cycle. When both indicating lamps "L1" and "A/kA" are on, the displayed value is the current of phase A. When both indicating lamps "L2" and "A/kA" are on, the displayed value is the current phase B. When both indicating lamps "L3" and "A/kA" are on, the displayed value is the current of phase C. As indicated in right figure, the current of phase B is 2150A.

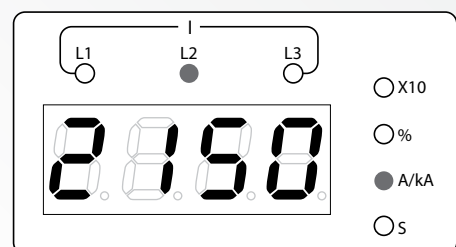

2. Manual selection display

In reset state, press "▲" or "▼" to manual selection display the related parameters, including : main contact wear rate, operation times of close/break, unsymmetrical grounding or leakage current, unbalance rate of A phase current, unbalance rate of B phase current, unbalance rate of C phase current, A phase current, B phase current, C phase current and N phase current (three poles ACB do not have this item).

The contents displayed in the current meter window are explained as following:

- ① When only the indicating lamp "%" is on, the displayed value is the wear rate of main contact of ACB, The controller factory-set is 100%. When the value $\leq 60\%$, system will give the self-diagnose alarm signal .After replacing the main contact of ACB, users can reset the wear rate as 100% by programmer or other special ways. As indicated in right figure, the wear rate of main contact is 100%.

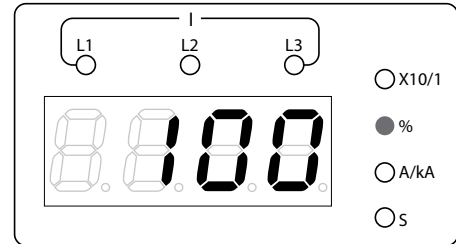

- ② When only the indicating lamp "x10/1" is on, the displayed value is the ACB close/break times presently. When the lamp is continuous on, the value x10 are the operation times; when the lamp is flashing, the value x1 are the operation times. This parameter can be modified by programmer or other special ways. The way "x10" or "x1" could be switched by special way; the default one is "x10". As indicated in right figure, the ACB switch close/break times are 70 at least.

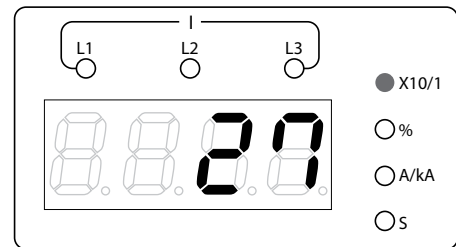

- ③ When the indicating lamp "If" and "A/kA" are both on, the displayed value is unsymmetrical grounding current or leakage current. As indicated in right figure, the grounding current is 1280A.

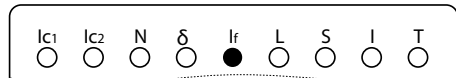
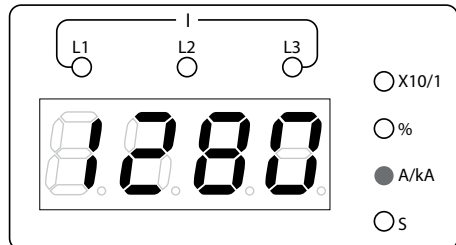

- ④ When the indicating lamps "δ","%" and "L1" are on, the displayed value is the unbalanced rate of phase A's current; "δ","%" and "L2" are on, the displayed value is the unbalanced rate of phase B's current; "δ","%" and "L3" are on, the displayed value is the unbalanced rate of phase C's current. As indicated in right figure, the unbalanced rate of phase A's current is 40%.

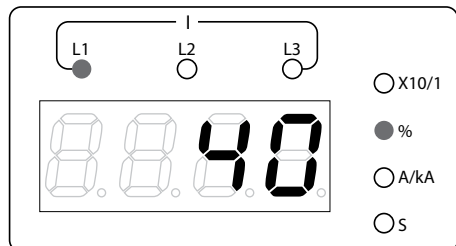

- ⑤ When the indicating lamps "L1" and "A/kA" are on, the displayed

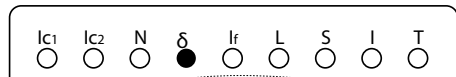

value is the current of phase A; when the indicating lamps "L2" and "A/kA" are on, the displayed value is the current of phase B; when the indicating lamps "L3" and "A/kA" are on, the displayed value is the current of phase C; when the indicating lamps "N" and "A/kA" are on, the displayed value is the current of N phase.(only in the 4 poles controller). As indicated in right figure, the current of B phase is 2150A.

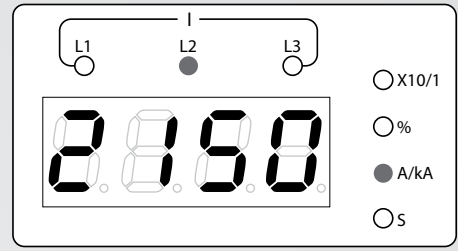

As indicated in right figure the current of phase N is 280A.

Note : When the indicating lamp "A/kA" is flashing, the unit of current value is kA; W when the lamp is continuous on, the unit of current value is A. The following in this manual is the same.

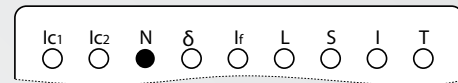
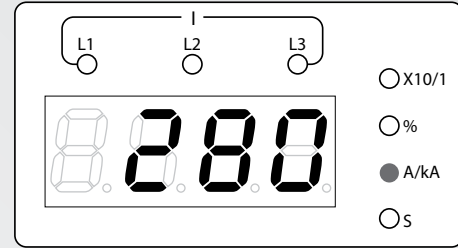

3. Automatic position display

The system will automatically display the fault phase current value or the unsymmetrical grounding current value when it in the fault alarm state. As in the right figure: the "L1" and "A/kA" are on, the protection types indicating lamp "L" is flashing, and the "ALARM" lamp is on, it is the phase A's current (3200A) provokes overload long delay fault alarm.

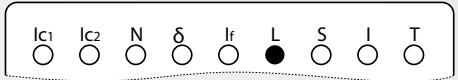
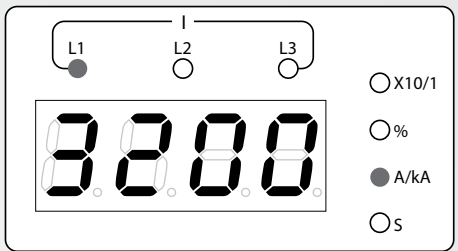

4. Fault operation display

After the controller trip, current meter window displays alternately the fault operation current value and the delay time value, protection types indicating region indicates fault types, operating state indicating region indicates the controller is in fault indicating state (the indicating lamp "FAULT" is on). The mode of display in functional meter window is not changed, still normally displayed. This fault current value is the detected maximum phase current, unsymmetrical grounding current or leakage current. As indicated in following figures:

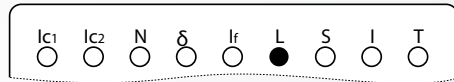
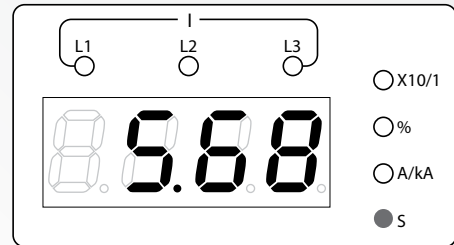
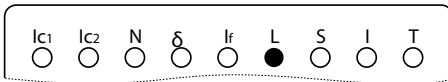
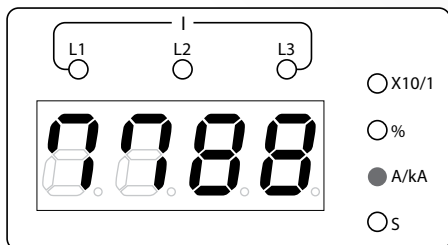
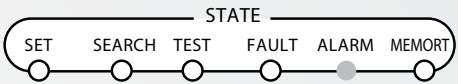

Note: After tripping, with normal power supply, it keeps the fault tripping display state of the trip time until the button "RETURN" is pressed. Press "▲" or "▼" to check other relative fault parameters, the method is the same as fault search (Detailed methods see 4.3.2)

9.2.3 The method of setting, search, test and system clock set

9.2.3.1 The method of parameters set

The method of parameters set as following:

1. Authority confirmed. For type H controller, the position lock must be turned to "SET"; otherwise, the parameters cannot be modified although system can get into parameter set state.
2. Confirm the controller is in reset state; if the controller is in other states, you can press "RETURN" until the current meter window in loop display state.
3. Press "FUNCTION" till the lamp "SET" flashes fast (once per second).
4. Press "ENTER", at this moment, the lamp "SET" flashes slow down (once in two seconds), it means the controller is in parameters choosing state; the current meter window shows the set current value of the overload monitor 1.
5. Press "▲" or "▼" to choose the needed set parameter.
6. Press "ENTER", at this moment, the lamp "SET" changes from slow flashing to continuous on, it means the controller is in parameter adjusting state; push "▲" or "▼" to get the needed value.
7. Press "ENTER", at this moment, the lamp "MEMORY" flashes once, it shows that the value has been memorized. (if the value are not changed, the lamp "MEMORY" does not flash), the system return to parameters choosing state automatically, press "RETURN" directly to abandon memory, the parameters remain the original value, the system return to parameters choosing state.
8. Repeat 5, 6, 7 to set other parameters; or press "RETURN" without setting, as the lamp "SET" is off, the system return to reset state.

Note : If the controller is in fault alarm state, the function of parameter set is locked; the parameters cannot be set. If fault happened during the parameter setting, the system quit the parameters set and get into fault state. The longer "▲" or "▼" is keep pressing, the faster the parameters change in parameters set state.

The following is the contents of current meter window and protection types indicating region, during setting different parameters in parameters set state.

In parameters set state, the current meter window indicates the set current value of the overload monitor 1 (the indicating lamp "A/kA" is on), protection types indicating region indicates overload monitor 1 (the indicating lamp "Ic1" is on). As indicated in right figure the set current value of overload monitor 1 is 2000A.

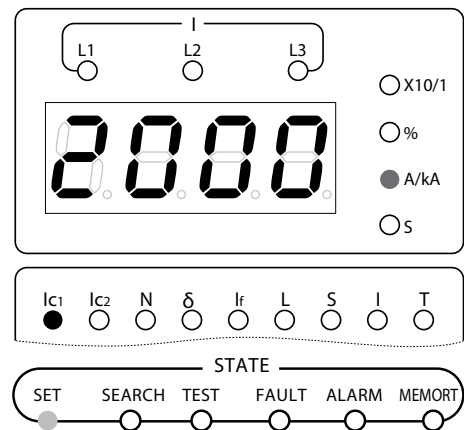

Press "▲" once, the current meter window indicates the set delay time of overload monitor 1 (the lamp "S" is on), protection types indicating region indicates it is overload monitor 1 (the indicating lamp "Ic1" is on); as indicated in right figure, the set delay time of overload monitor 1 is 8.00s.

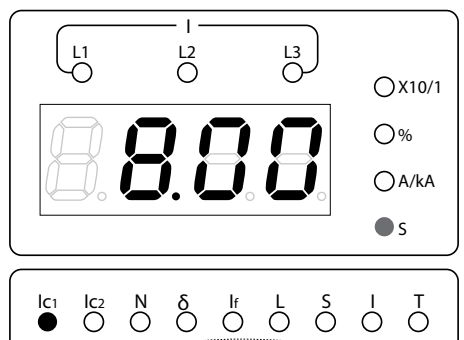

Press " ▲ " again, the current meter window indicates the set current value of the overload monitor 2 (the indicating lamp "A/kA" is on). Protection types indicating region indicates it is overload monitor 2 (the indicating lamp "Ic2" is on); as indicated in right figure the overload monitor 2 is in quit state.

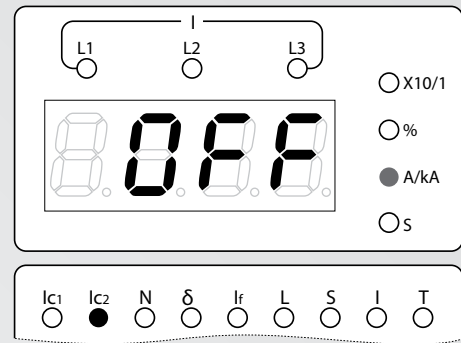

Press " ▲ " once more, the current meter window indicates the delay time of overload monitor 2 (the lamp "S" is on), protection types indicating region indicates it is overload monitor 2 (the indicating lamp "Ic2" is on); As indicated in right figure the set delay time of overload monitor 2 is 3.32s.

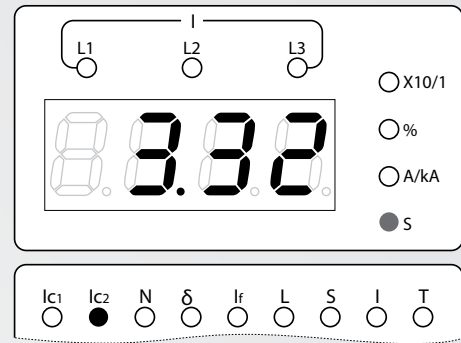

Press " ▲ " once more, the current meter window indicates the set value of phase N (the lamp "%" is on), protection types indicating region indicates it is phase N (the lamp "N" is on), it is only in the 4 poles controller; as indicated in right figure, the current of phase N was calculated as 100% in all protection.

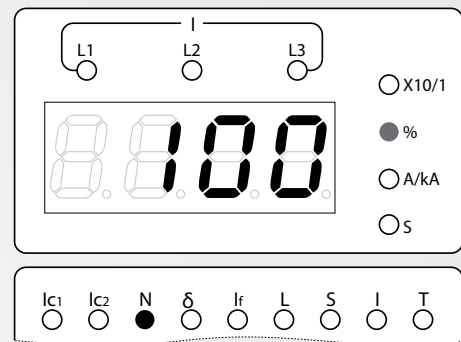

Press " ▲ " once more, the current meter window indicates the set unbalanced rate (the lamp "%" is on), protection types indicating region indicates it is current unbalance (the lamp "δ" is on). As indicated in right figure the set unbalanced rate is 90%.

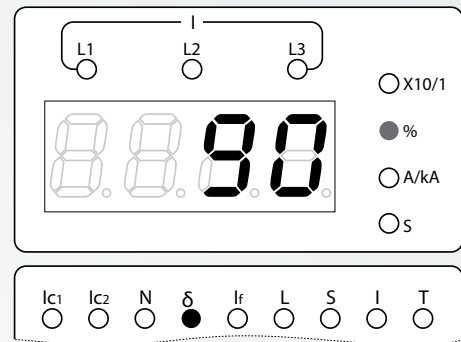

Press " ▲ " once more, the current meter window indicates the set delay time of current unbalance (the lamp "S" is on), protection types indicating region indicates current unbalance (the lamp "δ" is on); as indicated in right figure the set delay time of current unbalance is 0.30s.

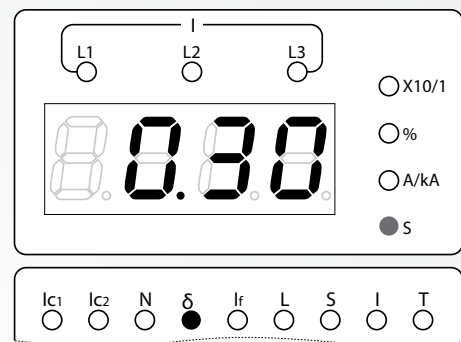

Press "▲" once more, the current meter window indicates the set unsymmetrical grounding current value or leakage current value (the lamp "A/kA" is on), protection types indicating region indicates unsymmetrical grounding or leakage (the lamp "If" is on); As indicated in right figure, the set unsymmetrical grounding current is 2000A.

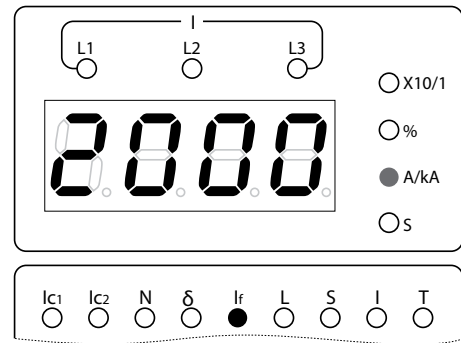

Press "▲" once more, the current meter window indicates the set value of unsymmetrical grounding and leakage inverse time-lag coefficient (the lamp "S" is flashing), protection types indicating region indicates unsymmetrical ground or electrical leakage (the lamp "If" is on); as indicated in right figure, the set value of unsymmetrical grounding inverse time-lag coefficient is 6.00.

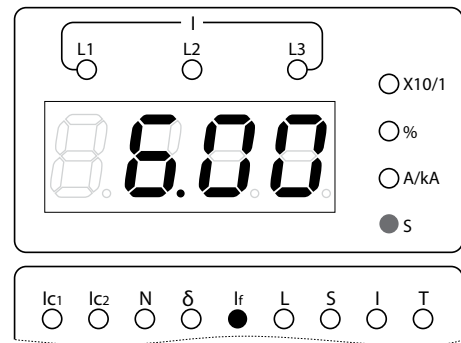

Press "▲" once more, the current meter window indicates the set delay time of unsymmetrical grounding or leakage (the lamp "S" is on), protection types indicating region means unsymmetrical grounding or leakage (The lamp "If" is on); as indicated in right figure, the set delay time of unsymmetrical grounding or leakage is 0.20s.

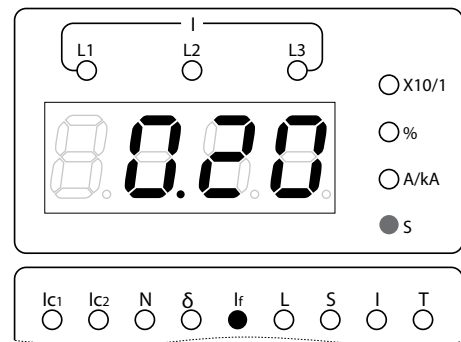

Press "▲" once more, the current meter window indicates the overload long delay set current (the lamp "A/kA" is on), protection types indicating region indicates overload long delay (the lamp "L" is on); as indicated in right figure the set overload long delay current is 2000A.

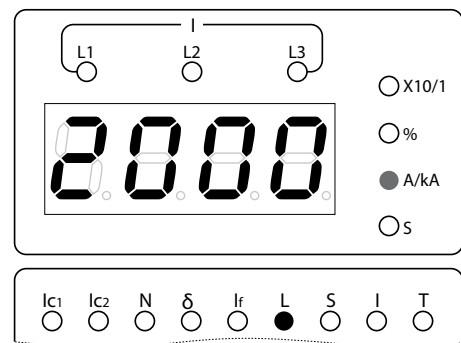

Press "▲" once more, the current meter window indicates the overload long delay set delay time (the Lamp "S" is on), protection types indicating region indicates overload long delay (the lamp "L" is on); as indicated in right figure the set overload long delay time is 433s.

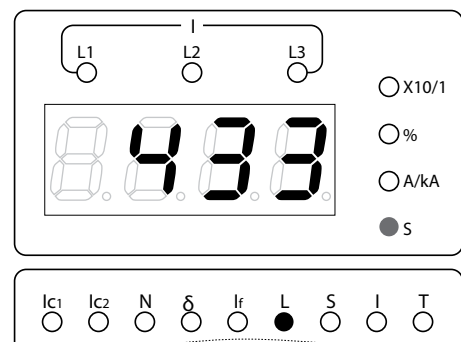

Press "▲" once more, the current meter window indicates the inverse time-lag set current of short-circuit short delay (the lamp "A/kA" is on), protection types indicating region indicates short-circuit short delay inverse time-lag (the lamp "S" is continuous on), As indicated in right figure the inverse time-lag set current of short-circuit short delay is 6300A.

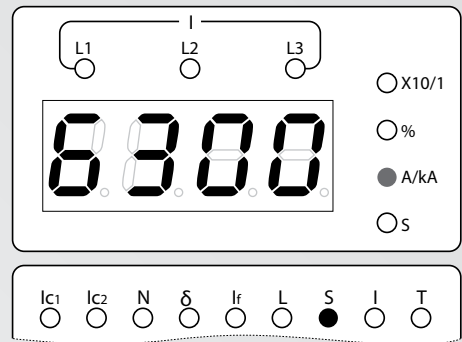

Press "▲" once more, the current meter window indicates the definite time-lag set current of short-circuit short delay (the Lamp "A/kA" is on), protection types indicating region means short-circuit short delay definite time-lag (the Lamp "S" is flashing); as indicated in right figure, the set definite time-lag current value of short-circuit short delay is 8000A.

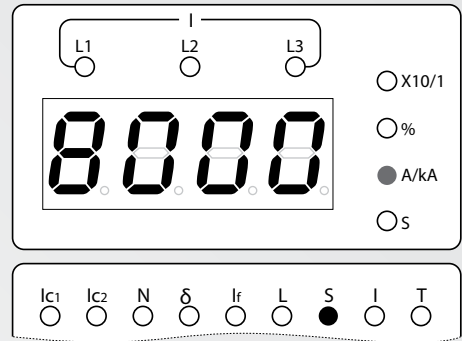

Press "▲" once more, the current meter window indicates the set delay time of short-circuit short delay (the lamp "S" is on), protection types indicating region means short-circuit short delay (the lamp "S" is on); as indicated in right figure, the set delay time of short-circuit short delay is 1.00s.

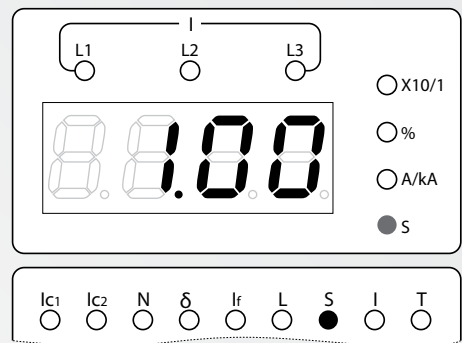

Press "▲" once more, the current meter window indicates the set value of short-circuit instant current (the Lamp "A/kA" is flashing), protection types indicating region indicates short-circuit instant (the lamp "I" is on); as indicated in right figure the set value of short-circuit instant current is 50.00kA.

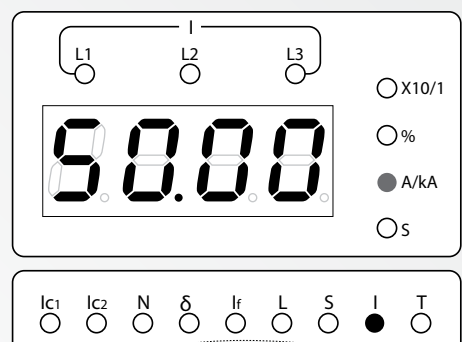

It is invalid to press the "▲" now; press "▼" to check selected set values backward again ; while one set values has been selected, press "▼" to check selected set values backward also till the set current value of overload monitor 1 indicated. value of overload monitor 1 indicated.

9.2.3.2 The method of fault search

The method of fault search is as following:

1. Confirm the controller is in reset state, if the controller is in other state, press "RETURN" until the current meter window is in loop display state.
2. Press "FUNCTION" , till the lamp "SEARCH" flash; press "ENTER" , then the lamp "SEARCH" becomes continuous on, it is in fault search state; the current meter window indicates alternately the fault trip current value and delay time.
3. Press "▲" or "▼" to check the relevant parameters, if fault occurs.
4. Press "RETURN" , then it indicates the fault trip current value and delay time alternately.
5. Press "RETURN" , until the lamp "SEARCH" is off, the system quit the fault search state, and return to reset state.

Note: If the controller is in fault alarm state, the function of fault search is locked and fault search is not available. If fault happen during the fault search state, the system will quit, and go into fault state.

The instruction of the fault search displayed content is as following:

The current meter window displays alternately fault trip current value and delay time value about the faults, as the figure below.

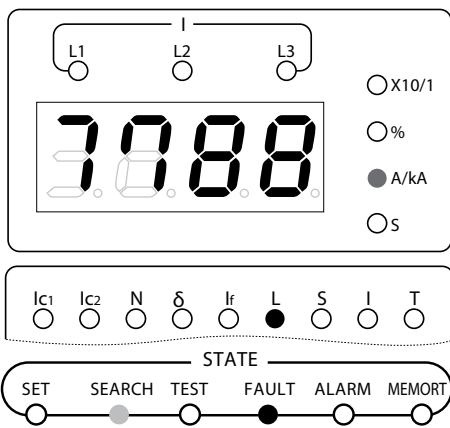

Overload with long time delay fault operation current

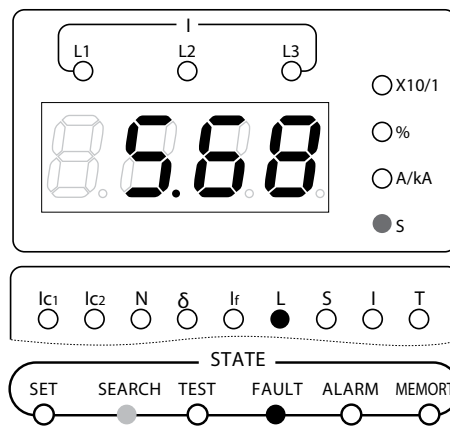

Overload with long time delay fault operation time

Press the "▲" and "▼" to check other relevant fault parameters.

Press "▲", the current meter window indicates the wear rate of main contact of ACB (only the lamp "% is on); the right figure indicates the wear rate of the main contact of ACB is 80%.

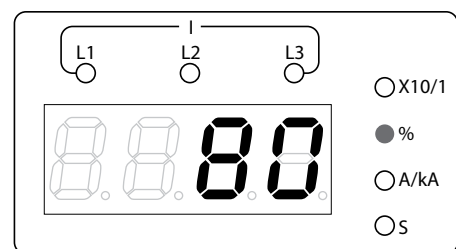

Press "▲" once more, the current meter window indicates close break times of the ACB (only the lamp "× 10/1" is on); as indicated in right figure the close/break times of the ACB is 270 at least.

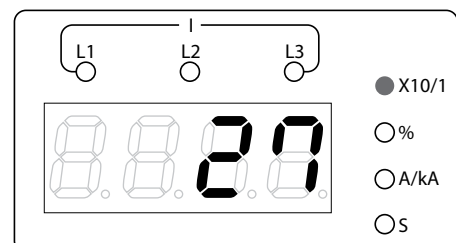

Press "▲" once more, the current meter window indicates

unsymmetrical grounding current or leakage current in fault state (only the lamp "A/kA" is on); protection types indicating region indicates it is unsymmetrical ground or electrical leakage (the lamp "If" is on); as indicated in right figure the unsymmetrical grounding current in fault state is 100A.

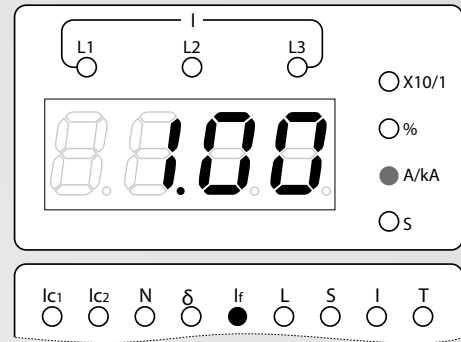

Press " ▲ " once more, the current meter window indicates unbalanced rate of phase A in fault state (the lamp "L1" and "%" are both on), protection types indicating region indicates current unbalance (the lamp " δ " is on); as indicated in right figure, the unbalanced rate of phase A in fault state is 200%.

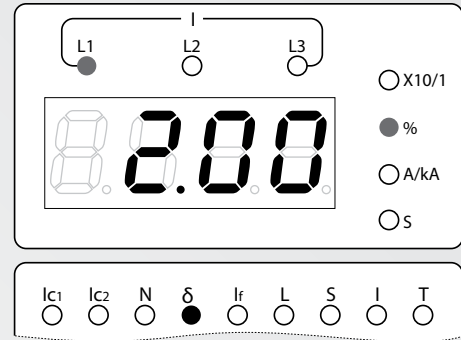

Press " ▲ " once more, the current meter window indicates unbalanced rate of phase B in fault state (the lamp "L2" and "%" are both on), protection types indicating region indicates current unbalance (the lamp " δ " is on); as indicated in right figure the unbalanced rate of phase B in fault state is 100%.

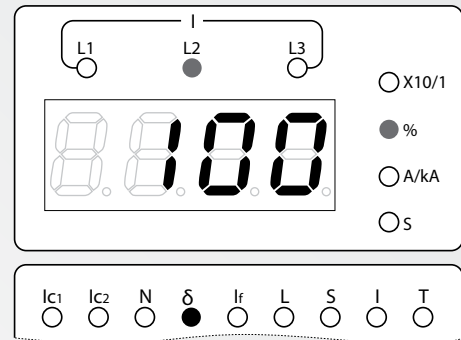

Press " ▲ " once more, the current meter window indicates unbalanced rate of phase C in fault state (the lamp "L3" and "%" are both on), protection types indicating region indicates current unbalance (the lamp " δ " is on); as indicated in right figure, the unbalanced rate of phase C in fault state is 100%.

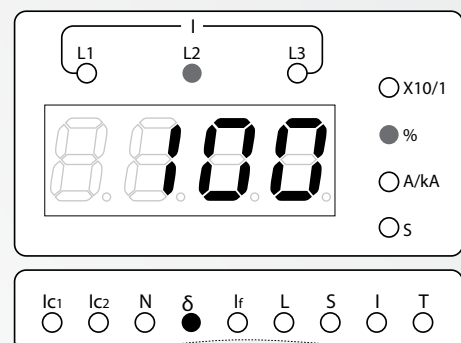

Press " ▲ " once more, the current meter window indicates the current of phase A in fault state (the lamp "L1" and "A/kA" are both on), as indicated in right figure, the current of the phase A in fault state is 7788A.

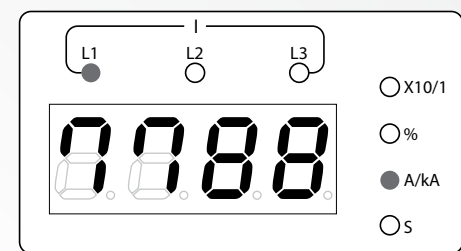

Press "▲" once more, the current meter window indicates the current of phase B in fault state (the lamp "L2" and "A/kA" are both on), as indicated in right figure, the current of the phase B in fault state is 0A.

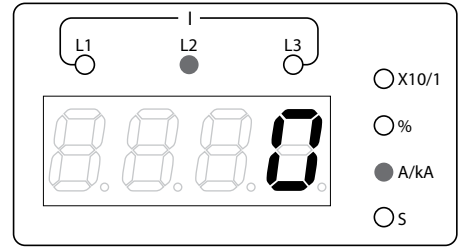

Press "▲" once more, the current meter window indicates the current of phase C in fault state (the lamp "L3" and "A/kA" are both on), as indicated in right figure, the current of the phase C in fault state is 0A.

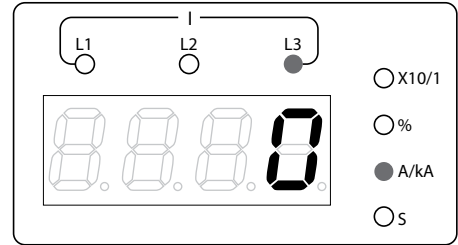

Press "▲" once more, the current meter window indicates the current of phase N in fault state (the lamp "A/kA" is on), protection types indicating region indicates it is phase N (the lamp "N" is on); only in the 4 poles controller; as indicated in right figure the current of phase N in fault state is 280A.

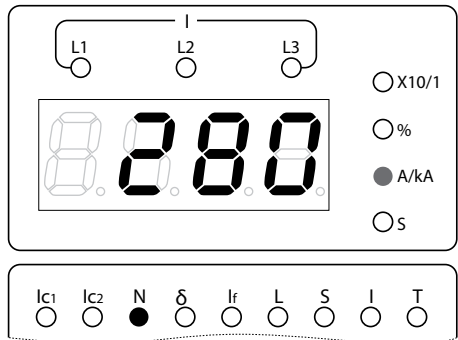

Press "▲" once more, the current meter window indicates the year and month of the fault happened (the lamp "L1" is flashing); as indicated in right figure the fault happened in June.2003

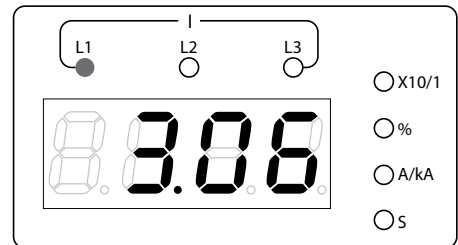

Press "▲" once more, the current meter window indicates the day and hour of the fault happened (the lamp "L2" is flashing); as indicated in right figure, the fault happened at 8:00 in 6th.

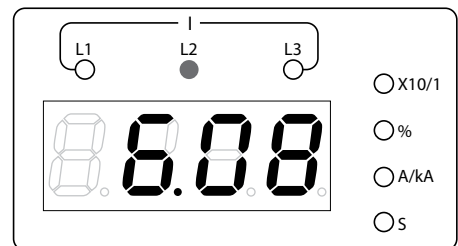

Press "▲" once more, the current meter window indicates the minute and second of the fault happened (the lamp "L3" is flashing); as indicated in right figure the fault was happened at 16"28".

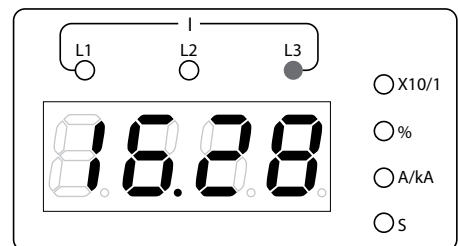

Note : Only system clock function is selected, the faults happen time can be indicated; otherwise, all three items of fault happened time will displays "-.-.-".

It is invalid to push the "▲" now; press "▼" to display relevant fault values backward again; while one set values has been selected, press "▼" to check selected set values backward also till the set value of main contact ware rate indicated.

9.2.3.3 The method of simulation test

The controller's simulation test has two types: one is instantaneous trip simulation test, which purpose is testing the match situation between controller and ACB; the other is no trip simulation test, which purpose is testing the protection feature of the controller.

(1) The method of instantaneous trip simulation test

1. Authority confirmed. For type H controller, the position lock must be turned to "SET"; otherwise, simulation test is not available.
2. Confirm the controller is in the reset state. If the controller is in other states, press "RETURN" until the current meter window is in loop display state.
3. Press "FUNCTION" until the lamp "TEST" flash fast (once per second).
4. Press "ENTER", the lamp "TEST" flash slow down (once in two seconds), it means ready for test.
5. Press "ENTER" again, the lamp "TEST" changes from slow flashing to continuous on, the system instantaneous trip, the ACB breaks, the current meter shows the break time.
6. Re-close the ACB, and press "ENTER" again, the system trip again, and the ACB is break again, the current meter shows the break time once more.
7. Press "RETURN", the lamp "TEST" changes from continuous on to fast flashing; Press "RETURN" again, the lamp "TEST" off; the system quits the test state.

If the controller operates normally during the instantaneous trip test, the current meter window will indicate trip time, if the ACB rejects to break; the current meter window will indicate the self-diagnose fault code "E-12". As the following figure:

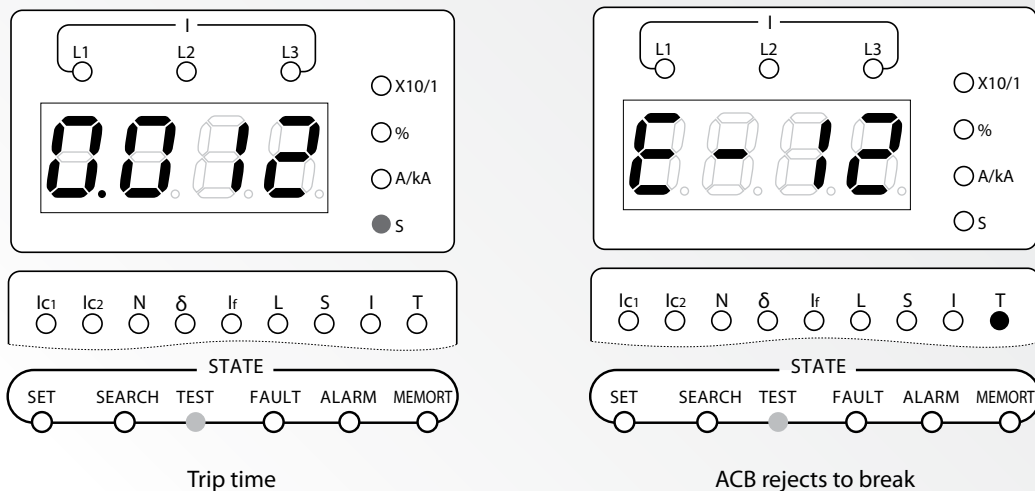

(2) The method of no trip test

- 1~4. The same as instantaneous trip simulation test.
5. Press "▲" or "▼" to choose test current; If press "▲", the current increases from $0.2I_n$, If press "▼", the current value decreases from 50.00kA (frame I) or 75.00kA (frame II) or 100.0 kA (frame III); press "▲", "▼" during the process to raise or reduce the value to get the needed test current.
6. Press "ENTER", the lamp "TEST" from slow flashing to continuous on, the system begin the delay process of no trip simulation test, its delay progress is similar to fault protection real progress; if the test current is too small or protection and monitor is quitted, the current meter window will display "nodo", it means the test is not implemented.
7. After the test is completed, the current meter window displays test current and the delay time under the test current alternately.
8. Press "RETURN", the lamp "TEST" changes from continuous on to fast flashing; press "RETURN" again, the lamp "TEST" off, the system quit test state.

Note: No trip simulation test covers all of protections and monitored operation, except current unbalance protection.
The relevant display contents of the controller in the no trip simulation test is as following:

If the test current is too small or the protection and monitor is quitted, the current meter window will display "nodo", it means no test; as right figure.

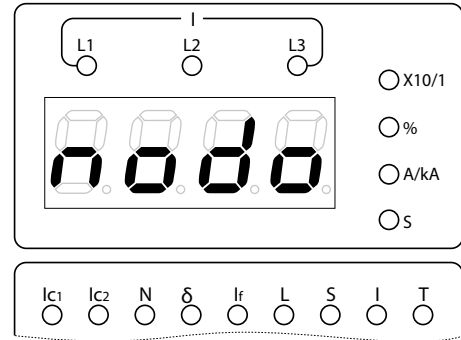

After the test is completed, the current meter displays alternately test current and delay time under this test current. The two following figures show the test results of overload long delay protection. Its test current is 4000A, delay time is 26.68s.

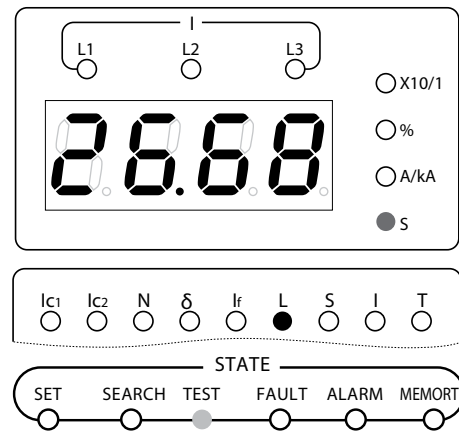
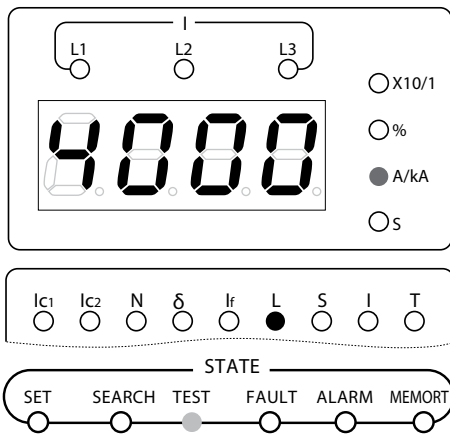

9.2.3.4 The method of self-diagnose fault search

The method of self-diagnose fault search is as following:

1. Confirm the self-diagnose fault search lamp "T" is on (means there are some self-diagnose fault information), and the controller is in reset state.
2. Press "ENTER", then current mater window displays the self-diagnose fault code, details are indicated as table 11.
3. If there are multiple diagnose faults, Press "▲", "▼" to check each fault code one by one in loop.
4. Press "ENTER" again to confirm the fault code already checked (some diagnose faults information would be cleared automatically when it quit, such as ACB rejects to break, E2PROM error and so on); for the single fault, it will quit self-diagnose search state.
5. Press "RETURN" to quit self-diagnose search state.

Self-diagnose fault codes are displayed as the right figure; "E-06" means transformer L3 wire broken.

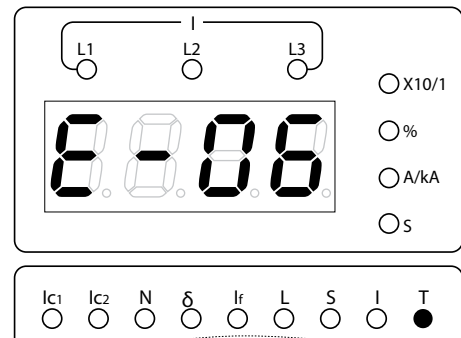

Table 10 : Self-diagnose fault codes

No.	Fault code	Meaning	No.	Fault code	Meaning
1	E-01	ROM error	8	E-08	Reserve
2	E-02	A/D converter error	9	E-09	Reserve
3	E-03	E2PROM error	10	E-10	Reserve
4	E-04	Transformer L1 wire broken.	11	E-11	Flux converter coil broken
5	E-05	Transformer L2 wire broken.	12	E-12	ACB reject to break
6	E-06	Transformer L3 wire broken.	13	E-13	Main contact maintain
7	E-07	Transformer L4 wire broken.	14	E-14	Ambient temperature excursion

Note : ROM error is a serious system fault, "E-01" automatically flashes fast in the current meter window and the system keeps self-test; if "E-01" flashes fast continuous, it means there are physical errors in ROM, the controller should be substituted.

9.2.3.5 The method of system clock set

The method of system clock set is as following:

1. Confirm added the system clock function already (default supplying does not include this function).
2. Authority confirmed. For type H controller, the position lock must be turned to "SET". Otherwise, the system clock can be checked but cannot be set.
3. When the controller is in reset state, and there are no self-diagnose faults (then lamp "T" is off), press "RETURN", and then press "ENTER" seven times immediately, a moment later, the lamp "SET" and "L1" simultaneous flash, it means it is in setting system clock state; the current meter window displays the year and month of the system clock.
4. Press "▲" or "▼" to choose the set content needed, the lamp "L1" flash means the contents are year and month, the lamp "L2" flashes means the contents are date and hour; the lamp "L3" flash means the contents are minute and second, press "ENTER", the lamp "SET" is on, it means in system clock set state.
5. Press "▲" or "▼" to set the time to an accurate value.
6. Press "ENTER", at this moment, the lamp "MEMORY" flashes one time means the set value has been memorized (if the value doesn't change, the lamp would not flash), and the system return to choosing state automatically. Press "RETURN" directly, the clock maintain the original value without memory, the system return to choosing state.
7. If other contents set needed, repeat 4,5,6; if not, press "RETURN" till the lamp "SET" is off, the system quits system clock set state and return to reset state.

Note: If the system clock function is not added, system displays "noSC" (No System Clock), when it is in system clock

setting state, it means no system clock, indicated as the right figure:

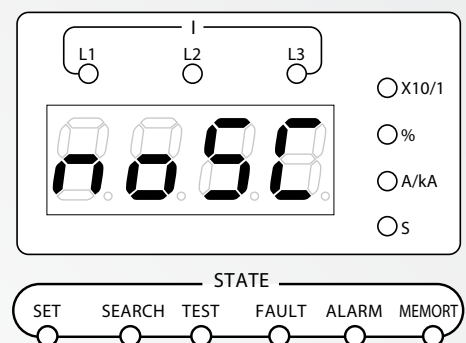

The display contents during system clock set process are as follows:
Enter system clock set state, "L1" is flashing, means the set content are month and year; as indicated in right figure the date is in June.2003.

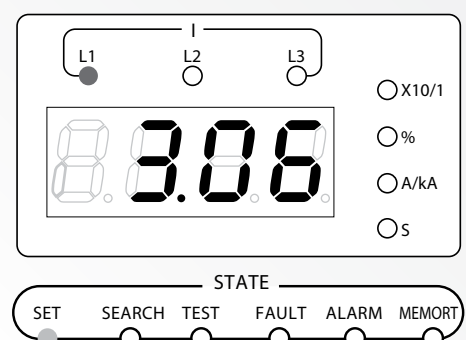

Press "▲"; "L2" is flashing, means the setting contents are hour and day, as indicated in right figure, the date and time is at 8:00 in 6th.

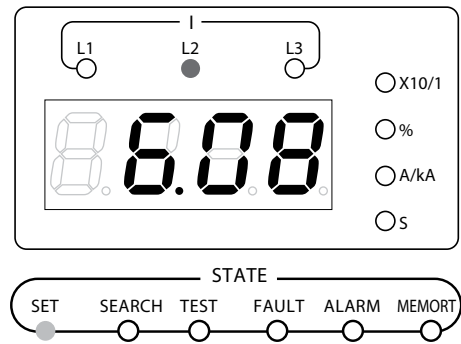

Press "▲" again, "L3" is flashing, means the setting content is minute and second, as indicated in right figure the time is at 16"28".

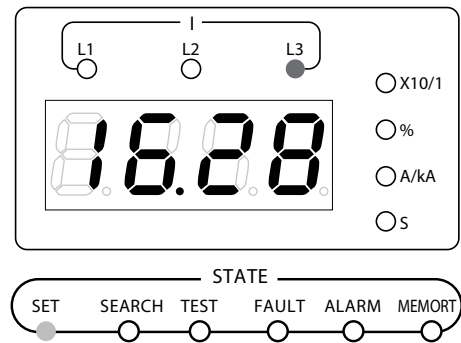

Note: When it is in choosing state in the adjusting system clock process, the system indicates the time dynamically (once in two seconds)

The three operating states of parameters set, the button "FUNCTION" switches fault search and simulation test. In normal state, press "FUNCTION" continuously, the three operating states are switched in turn. When a state is selected, the operating state lamp ("SET", "SEARCH" or "TEST") flashes press "ENTER" again to enter this state.

When it is in states of parameters set, fault search, simulation test, self-diagnose fault search, system clock set etc, if no button be pressed in 5 minutes, the system will return to reset state automatically; if faults happened in the mentioned above states, the system will quit the state and get into fault alarm state.

9.2.4 The methods of other parameters setting

The controller's other parameters (such as the types of characteristic curves, thermal memory, programmable signal contact output, communication protocol, communication address, communication baud rate, function lock, voltage connection mode and so on) can be set by programmer or other special methods. These values has been set as default values in factory, the users do not need to change the parameters except communication network assembly; order special purchases to meet special needs, the operation of the programmer will show in "KST programmer operating instruction".

9.2.5 Communication state display

The light of TxD shins when the H controller is in transmit state in "remote" communication or programmer working, the light of RxD shins while it in receive state.

There are programming interface in M controller communicate with programmer. It runs normally while there is not RxD and TxD lights.

9.3 Plugging into and drawing out of the breaker

9.3.1 How to plug into the breaker

Pull out around saddles of the drawer seat and put breaker body onto it, then push saddles into the drawer set, at last, turn the handle clockwise. During this process, the breaker is pushed from "disconnected" will be heard. It indicates that breaker body has been connected to its place. When the breaker gets to "connected" position, two sounds of click occurs.

9.3.2 How to draw out the breaker

Turning handle counter clockwise can draw out the breaker, which is in "connected" position. It needs to pull out the handle to draw out the breaker body from drawer seat when indicator means to "disconnected" position (It cannot be drawled out unless handles has been pulled out).Firmly grasping the handle can remove the breaker from drawer seat.

Breaker must be disconnected before plugging into drawer seat. The breaker in Test position, whose secondary circuit has been **connected, is allowed to be test.**

9.4 Maintenance

9.4.1 Routine cleaning to keep insulated well.

9.4.2 Inject lubricating oil (to the axletree part) and consistent grease (to the gears and other slide parts)

9.4.3 Inspect the contact system and the mechanism periodically.

- a. Check the arc-extinguishing chamber and the wear state of contacts. Measure opening distance and contact over travel if necessary. When the contact over travel is being measured, the displacement between moving contacts and contact sustainer can be checked. When the breaker is closing, make a mark on contact sustainer (at the point of arcing horn of moving contact). Then break the breaker and measure the displacement of the moving contacts, which multiplied by 28/53 is the over travel of contacts. This value should not less than 4mm.
- b. Check that if fastening units are loose or not, namely any drop or invalidation.
- C. Check that if acting distance of under-voltage release, shunt release or closing electromagnet has surplus or not. Surplus of closing electromagnet should be about 1mm. Others should be large than 1mm.
- d. Check that if operation characteristics of all accessories conform to requirements or not.
- e. Fill in 1mm thick horseshit scrip or other relevant material between moving contacts and fixed contacts, and the breaker should be closed reliably. Please be careful when filling in.

9.4.4 It is necessary to renew motor-driven energy-storage mechanism, main contacts, spring of energy-storage mechanism if it achieves medical life without maintenance.

9.4.5 After breaking of short-circuit, the checking content is the same as above. Further more, the flexible connection with its jointing part should be checked. In addition, they should not have obvious failure; otherwise, the broken parts should be renewed. Rene arc-extinguishing chamber and contact system in time when the breaker gets to its electrical life.

10. Regular failure and obviate methods

Serial Number	Situation	Possible causes	Suggestions
1	Circuit breaker does not close	<ol style="list-style-type: none"> 1. Power supply has not be connected to under-voltage release 2. The red button in controller is not reset after tripping 3. Operating mechanism has not stored energy 	<ol style="list-style-type: none"> 1. Check circuit and switch on power supply 2. Press reset button 3. Store energy with manual method (energy-storage will be indicated and "click" sound will be heard after cradling handle up and down seven times), or motor driven method.
2	Circuit breaker does not store energy	<ol style="list-style-type: none"> 1. Power supply of the motor-driven mechanism has not been switched on. 2. Power capacity is not enough. 	<ol style="list-style-type: none"> 1. Checking circuit and switch on power supply. 2. Make sure that operating voltage more than 85%Ue °
3	Circuit breaker can not be closed by closing electromagnet	<ol style="list-style-type: none"> 1. There is no supply voltage. 2. Power capacity is not enough 	<ol style="list-style-type: none"> 3. Checking circuit and switch on power supply. 4. Make sure that operating voltage more than 85%Ue °
4	Circuit breaker can not be broken by shunt release tripping	<ol style="list-style-type: none"> 1. There is no supply voltage. 2. Power capacity is not enough. 	<ol style="list-style-type: none"> 5. Checking circuit and switch on power supply. 6. Make sure that operating voltage more than 70%Ue °
5	Only instantaneous tripping but no delay tripping when fault current exceeds short time delay current, instantaneous current and overload long time delay current	The setting value of short time delay and the instantaneous tripping are not reasonable, which are set in the same range.	Setting is improper. Please set again according to $I_{r3} > I_{r2} > I_{r1}$ principle.
6	Breake trips frequently	The overload protection tripping is caused by overload running in field. Re-close breaker without eliminating overload thermo-memory in time.	Switch off the controller one time or re-close the breaker after 30 minutes.
7	Handle of wtihdrawable breaker cannot be plugged into breaker. Withdrawable breaker body can not be drawn out at disconnection position	Lead rail or breaker body has not been pushed into its position.	Push lead rail or breaker body into its position.
8	Withdrawable breaker body can not be drawn out at disconnection position	<ol style="list-style-type: none"> 1. Handle has not been pulled out 2. Breaker is not totally on disconnection position. 	<ol style="list-style-type: none"> 1. Pull out the handle 2. Make the breaker totally on disconnection position.
9	No screen on controller	<ol style="list-style-type: none"> 1. No input power 2. The load less than 40% 	<ol style="list-style-type: none"> 1. #1 and #2 connect with lutput power 2. The load shall be more than 40% before connection input power.



Date : Y M D

Fill in plus $\sqrt{\quad}$ or value

Customer :		Order number :		Delivery required : Y M D	
Type : BA-		Quantity :		PCS	Number of poles : <input type="checkbox"/> 3P <input type="checkbox"/> 4P
Rated current: <input type="checkbox"/> 630A <input type="checkbox"/> 800A <input type="checkbox"/> 1000A <input type="checkbox"/> 1250A <input type="checkbox"/> 1600A <input type="checkbox"/> 2000A <input type="checkbox"/> 2500A <input type="checkbox"/> 3200A <input type="checkbox"/> 4000A <input type="checkbox"/> 5000A <input type="checkbox"/> 6300A		Frame : <input type="checkbox"/> 2000 <input type="checkbox"/> 3200 <input type="checkbox"/> 4000 <input type="checkbox"/> 5000 <input type="checkbox"/> 6300		Connection : <input type="checkbox"/> Horizontal (Standard) <input type="checkbox"/> Vertical	
		Installation type: <input type="checkbox"/> Draw out type <input type="checkbox"/> Fixed type		Length for Draw out tool : <input type="checkbox"/> Standard <input type="checkbox"/> Longer type	
Parameter selection of intelligent controller	Type	<input type="checkbox"/> KST45-2M (Standard) <input type="checkbox"/> KST45-2H			
	Setting parameter	Ir1 = A T _L = S ; Ir2 = A T _s = S Ir3 = A I _f = A T _G = S Standard setting are as follows : Ir1 = In 0T _L = 20S ; Ir2 = 4In T _s = 0.4S Ir3 = 5In I _f = 0.8In T _G = 0.4S Characteristic of tripping curve is posthaste inverse-time delay.			
	Earthing protection mode	<input type="checkbox"/> vector <input type="checkbox"/> external transformer <input type="checkbox"/> OFF (Standard is vector)			
	Load monitoring mode	<input type="checkbox"/> mode 1 <input type="checkbox"/> mode 2 <input type="checkbox"/> OFF (Standard setting is mode 1)			
	Auxiliary function	<input type="checkbox"/> power mete <input type="checkbox"/> signal unit <input type="checkbox"/> MCR Overload thermo-memory characteristic (<input type="checkbox"/> ON <input type="checkbox"/> OFF) short-time delay thermo-memory characteristic (<input type="checkbox"/> ON <input type="checkbox"/> OFF) (Standard for first to third items is non-selection, for last two items is ON.)			
	Power supply	<input type="checkbox"/> AC380V <input type="checkbox"/> AC220V/230V <input type="checkbox"/> DC220V <input type="checkbox"/> DC110V (Standard is AC220V/230V)			
Indispensable accessories (Standard is AC220V)	Shunt release :	<input type="checkbox"/> AC380V <input type="checkbox"/> AC220V <input type="checkbox"/> DC220V <input type="checkbox"/> DC110V			
	Closing electromagnet :	<input type="checkbox"/> AC380V <input type="checkbox"/> AC220V <input type="checkbox"/> DC220V <input type="checkbox"/> DC110V			
	Energy-storage motor :	<input type="checkbox"/> AC380V <input type="checkbox"/> AC220V <input type="checkbox"/> DC220V <input type="checkbox"/> DC110V			
	Auxiliary switch :	<input type="checkbox"/> 4NO 4NC(Standard) <input type="checkbox"/> 6NO 6NC			
Optional accessories	Under-voltage controller	Voltage grade : <input type="checkbox"/> AC380V/400V <input type="checkbox"/> AC220V/230V Acting time : <input type="checkbox"/> instantaneous <input type="checkbox"/> 0~1 S <input type="checkbox"/> 1~5 S			
	ST-DP protocol module	<input type="checkbox"/> unit			
	ST power supply Module	<input type="checkbox"/> unit			
	ST hand-held programmer	<input type="checkbox"/> unit			
	External current transformer	<input type="checkbox"/> unit load circuit mode <input type="checkbox"/> ZCT1 , <input type="checkbox"/> ZT100) ratio (:)			

Note1 : It is necessary to choose “external current transformer” in accessory column if “external transformer mode” is chosen for earth-fault protection.

Note 2 : Non-selection is namely identified with standard if it is marked with standard.



Molded Case Circuit Breaker/
Earth Leakage Circuit Breaker

Breaker & Switchgear System



Air Circuit Breaker



Automatic Transfer
Switches



Miniature Circuit
Breaker

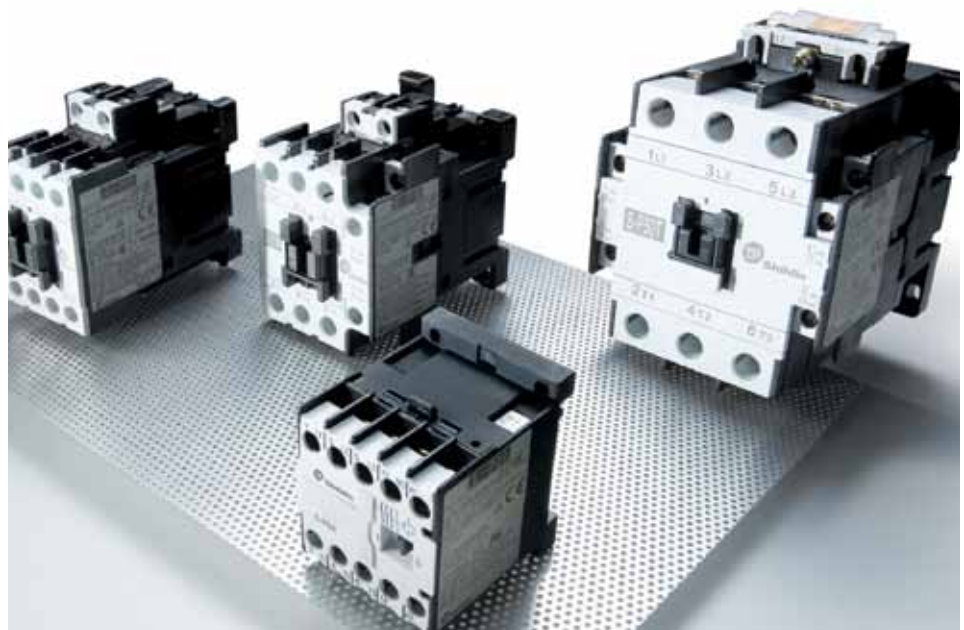

Magnetic Switch / Contactor



Surge Protective
Device



Digital multi-meter



Inverter



Capacitor

SHIHLIN ELECTRIC & ENGINEERING

Air Circuit Breaker, Molded Case Circuit Breaker, Earth-Leakage Circuit Breaker, Electronic Molded Case Circuit Breaker, Miniature Circuit Breaker, Residual Current Circuit Breaker, Automatic Transfer Switches, Magnetic Switch, Surge Protective Device, High / Low Voltage Power Capacitors, Digital Multi-Meter, Inverter



www.seec.com.tw

Head Office

16F, No.88, Sec.6, ChungShan N.Rd., Taipei, Taiwan,111
T. +886-2-2834-2662 F. +886-2-2836-6187

International Sales Dept.

3F, No.9, Sec.1, Chang-An E. Rd., Taipei, Taiwan,104
T. +886-2-2541-9822 F. +886-2-2581-2665
e-mail. b.export@seec.com.tw

